

W E R T H E R

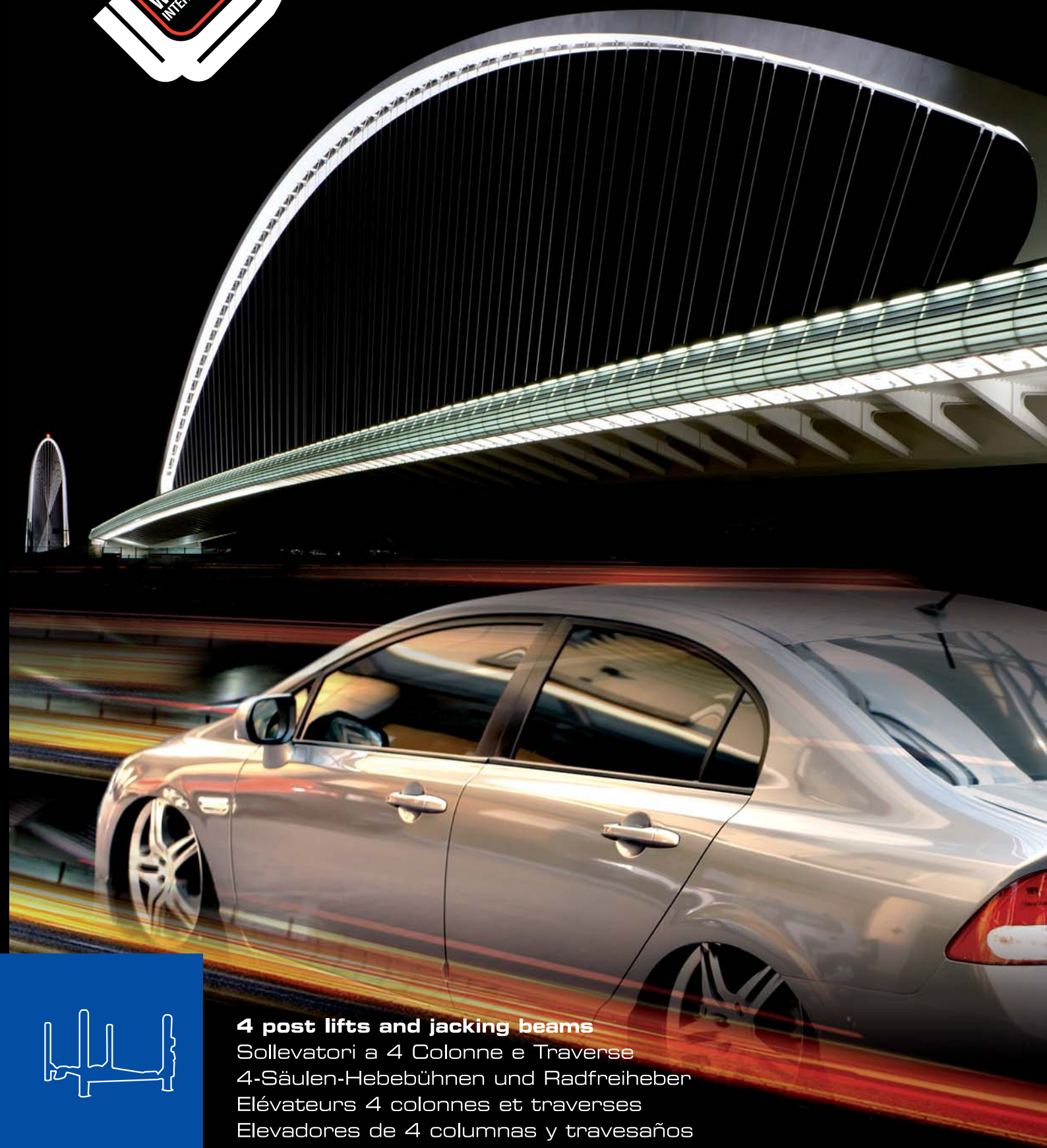

4 post lifts and jacking beams

Sollevatori a 4 Colonne e Traverse
4-Säulen-Hebebühnen und Radfreiheber
Elévateurs 4 colonnes et traverses
Elevadores de 4 columnas y travesaños



W E R T H E R





WERATHER INTERNATIONAL



HH LIONS UK
London, England



TECALEMIT UK
Plymouth, England

WERATHER BY NUMBERS

Founded by Mr. Enea Zanini and Mr. Werther Iori in 1970

- 12 company branches
- Total revenue: 145 million EURO
- 340 worldwide staff
- 42 year market presence
- Strategic worldwide locations
- 57 authorized distributors worldwide
- 89 authorized service centres
- Customers Support in 97 countries
- Major O.E.M supplies
- 23 production / commercial / warehouse sites
- 174.000 Sq.mt. of facilities
- 6 week lead-time from manufacturer to installation site

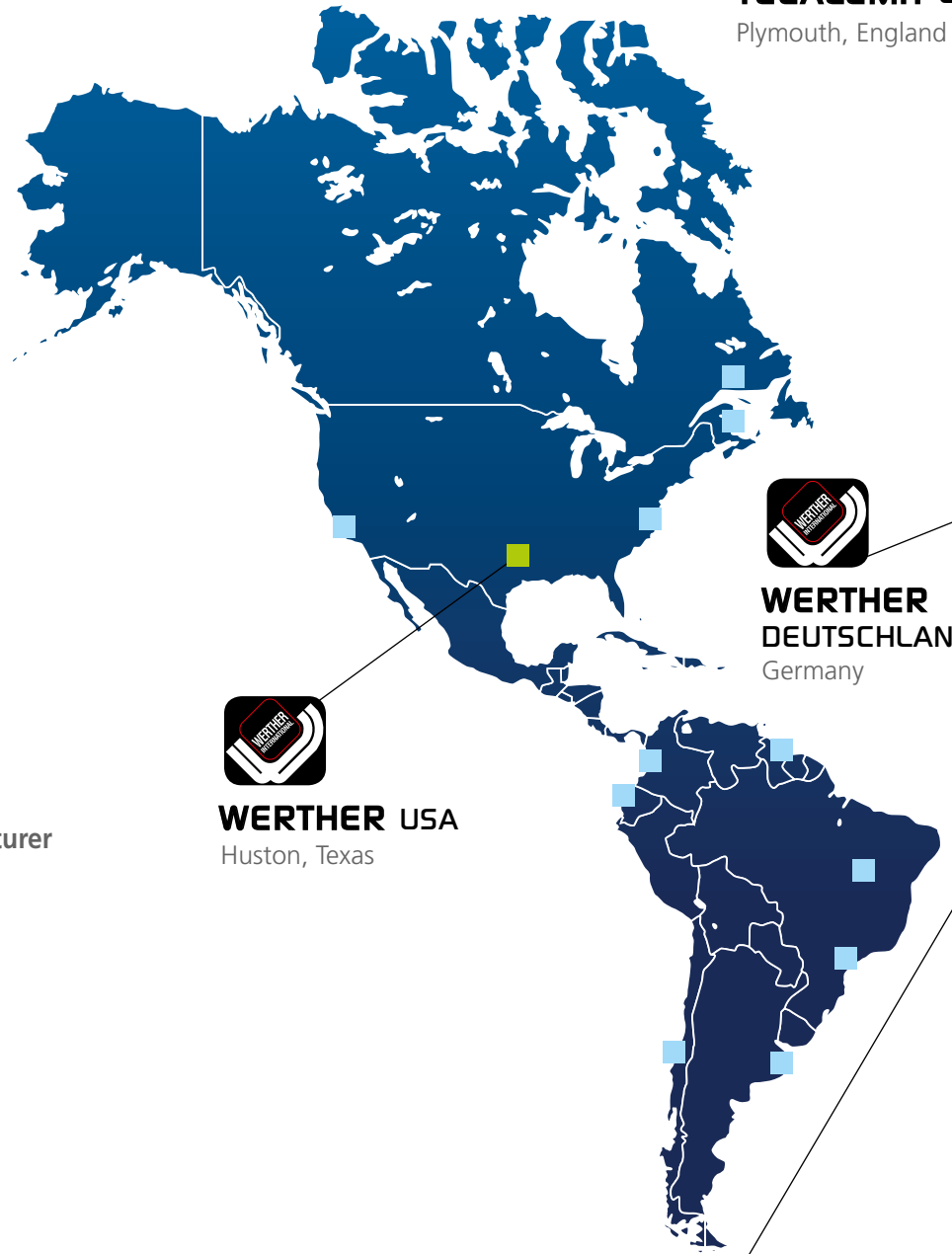

WERATHER DEUTSCHLAND
Germany



WERATHER USA
Huston, Texas



WERATHER IBERICA
Barcelona, Spain



Company Branches



Partners



Authorized Distributors



EGi FRANCE
Vierzon, France



Vierzon, France



INTERTECH
Copenhagen,
Denmark



WERATHER POLSKA
Poland



EGi POLAND
Poland

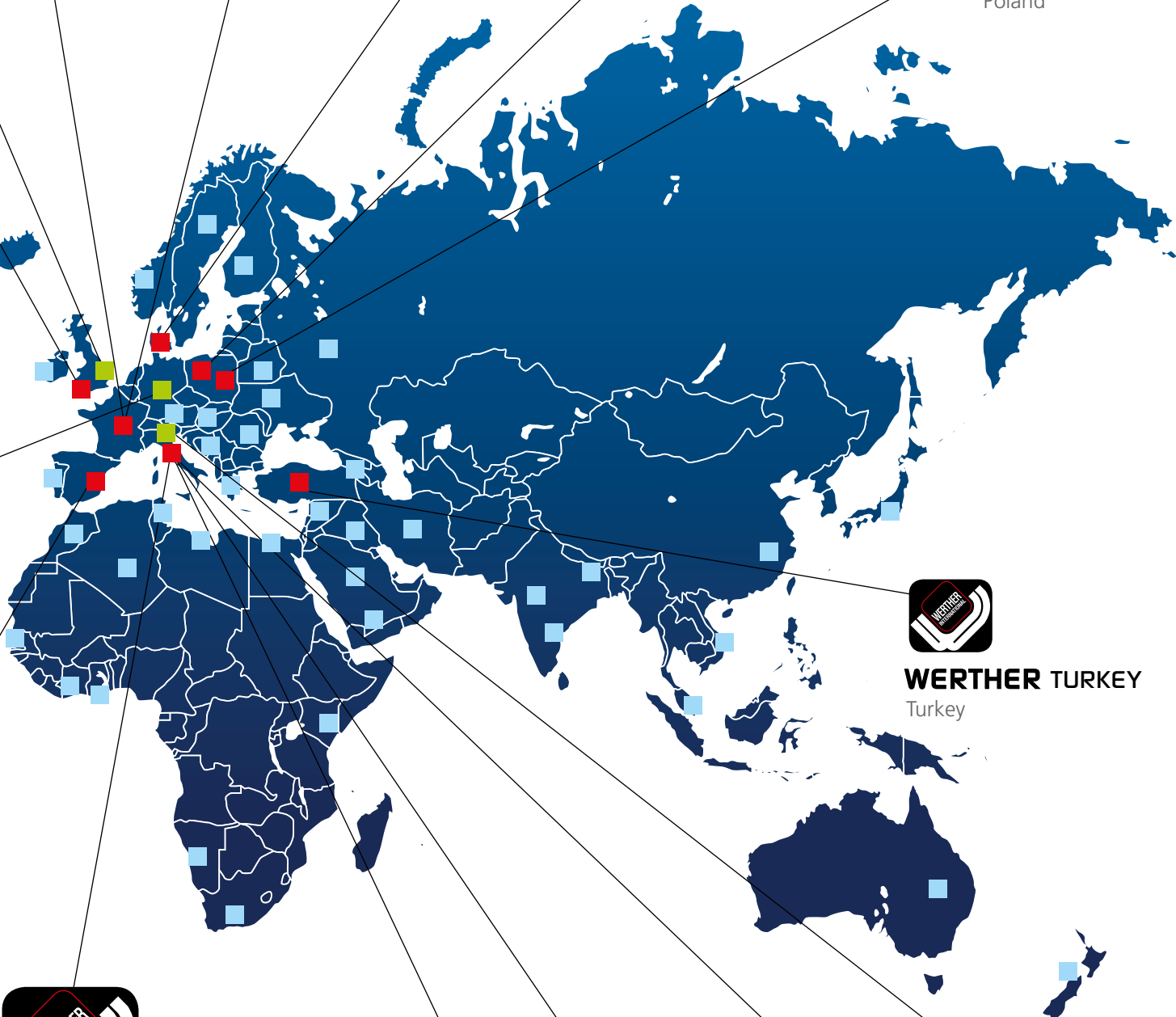

WERATHER TURKEY
Turkey



W E R T H E R

Via F. Brunelleschi, 12 - 42124 Cadè (RE) Italy
Tel. +39 0522 9431 +39 346 98 37 325 +39 346 98 37 443
Fax +39 0522 941997 e-mail: sales@wertherint.com

www.wertherint.com



Vicenza, Italy



Vicenza, Italy



Reggio Emilia, Italy



WT Engineering
Bergamo, Italy

The company reserves the right to introduce improvements in design or specification without prior notice

www.wertherint.com







436





3,5 t

CE



-  Sollevatore elettroidraulico a 4 colonne
-  **Electro-hydraulic 4 post lift**
-  Elektrohydraulische 4-Säulenbühne
-  Pont élévateur électro-hydraulique 4 colonnes
-  Elevador electro-hidráulico de 4 columnas

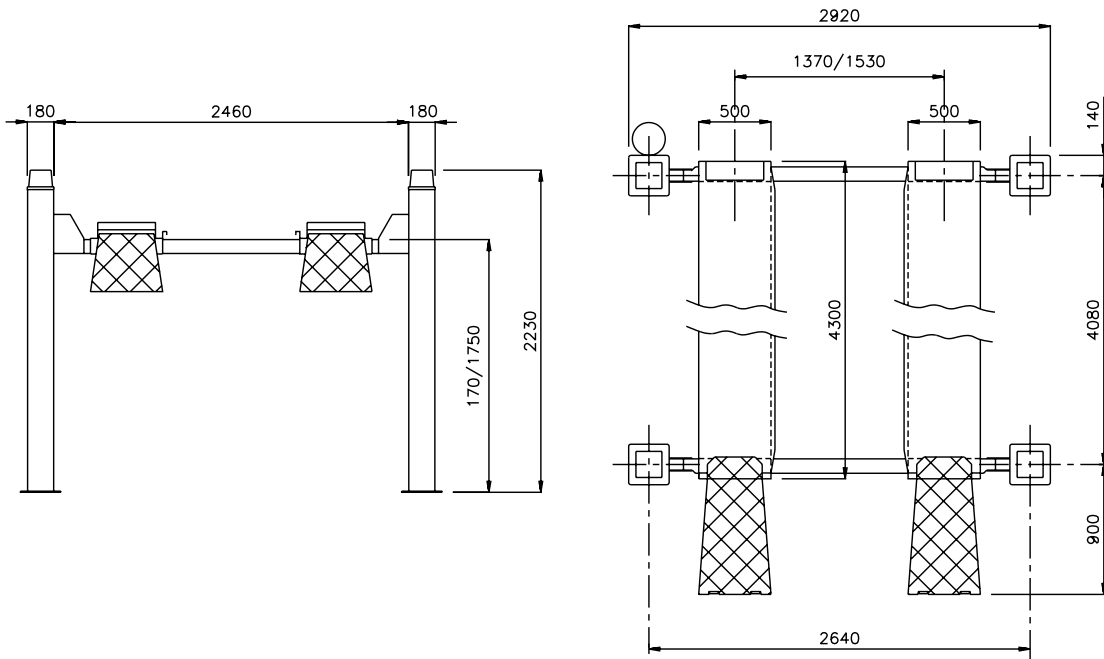

-  Sicurezza idraulica contro il sovraccarico • Valvola regolazione discesa • Segnale acustico ultimo tratto di discesa • Sicurezza idraulica in caso di rottura tubi idraulici • Comandi uomo presente 24 V • Sgancio elettrico del sistema di sicurezza meccanico
-  **Overload safety valve • Descent control valve • "Buzzer" on last portion of descent • Pipe burst safety valve • 24 V, low tension dead man controls • Automatic release of safety locking devices**
-  Überdruckventil gegen Überlastung • Senksteuerventil • Akustisches Signal im letzten Teil der Senkbewegung • Rohrbruchsicherung • 24 V-Totmann-Steuerung • Elektrische Entriegelung der mechanischen Lastsicherung
-  Vanne de surpression contre surcharges • Vanne de réglage descente • Signal sonore sur la dernière partie de descente • Vanne d'arrêt en cas de rupture de la tuyauterie • Commandes de type homme mort à 24 V • Déverrouillage électrique du système de sécurité mécanique
-  Seguridad hidráulica contra la sobrecarga • Válvula de regulación del descenso • Señal acústica último tramo de descenso • Seguridad hidráulica en caso de rotura tubos hidráulicos • Mandos de hombre presente, 24V • Desenganche eléctrico del sistema de seguridad mecánico

**Dati tecnici****Technical data****Technische Eigenschaften****Caractéristiques techniques****Datos técnicos**

Portata	Capacity	Tragfähigkeit	Capacité	Capacidad	3.500 kg
Peso	Weight	Gewicht	Poids	Peso	830 kg
Salita/Discesa	Lifting/descent	Hub/Senkzeit	Levage/descente	Subida/Bajada	50/45 s
Altezza di sollevamento	Lifting height	Hubhöhe	Hauteur de levage	Altura de elevación	1750 mm
Motore	Motor	Motorleistung	Puissance moteur	Motor	2,2 kW - 3 ph 230 400V/50 Hz

Funzionamento: Elettroidraulico • **Operation: Electro-hydraulic** • Funktionsweise: Elektrohydraulisch • Fonctionnement: Electrohydraulique • Funcionamiento: Electro-hidráulico

Opzioni
Optionals
Sonderzubehör
Options
Opcionales

Traversa idraulica ausiliaria (vedere scheda specifica)
Hydraulic jacking beam (see relevant data sheet)
 Hydraulischer Radfreiheber (s. eigenes Datenblatt)
 Levage auxiliaire hydraulique (voir fiche technique)
 Elevador hidráulico auxiliar (ver ficha técnica)

Esecuzione con motore monofase • Kit illuminazione • Carter protezione centralina

Single-phase motor • Illumination kit • Cover for control unit

Ausführung mit Einphasenmotor • Beleuchtungsset • Abdeckung für Hydraulikaggregat

Moteur monophasé • Kit d'éclairage • Carter protection centrale hydraulique

Motor monofásico • Kit de iluminación • Cubierta protectora para la centralita







442 LP





4,0 t

CE



-  Sollevatore elettroidraulico a 4 colonne
-  Electro-hydraulic 4 post lift
-  Elektrohydraulische 4-Säulenbühne
-  Pont élévateur électro-hydraulique 4 colonnes
-  Elevador electro-hidráulico de 4 columnas



-  Alta velocità di sollevamento • Sicurezza idraulica contro il sovraccarico • Valvola regolazione discesa • Segnale acustico ultimo tratto di discesa • Sicurezza idraulica in caso di rottura tubi idraulici • Comandi uomo presente 24 V • Sgancio automatico delle sicurezze per la discesa
-  High lifting and descent speed • Overload safety valve • Descent control valve • "Buzzer" on last portion of descent • Pipe burst safety valve • 24 V, low tension dead man controls • Automatic release of safety locking device
-  Hohe Hub- und Senkgeschwindigkeit • Überdruckventil als Überlastsicherung • Senksteuerventil • Akustisches Signal im letzten Teil der Senkbewegung • Rohrbruch-Sicherheitsventil • 24 V-Totmannschaltung • Automatische Entriegelung der Lastsicherungshebel vor dem Absenken
-  Grande vitesse de levage et descente • Vanne de surpression contre surcharges • Vanne de réglage descente • Signal sonore sur la dernière partie de descente • Vanne d'arrêt en cas de rupture de la tuyauterie • Commandes de type homme mort à 24 V • Déclenchement automatique des crochets lors de la descente
-  Alta velocidad de elevación • Seguridad hidráulica contra la sobrecarga • Válvula de regulación del descenso • Señal acústica último tramo de descenso • Seguridad hidráulica en caso de rotura tubos hidráulicos • Mandos de hombre presente, 24V • Desenganche automático de las seguridades para el descenso

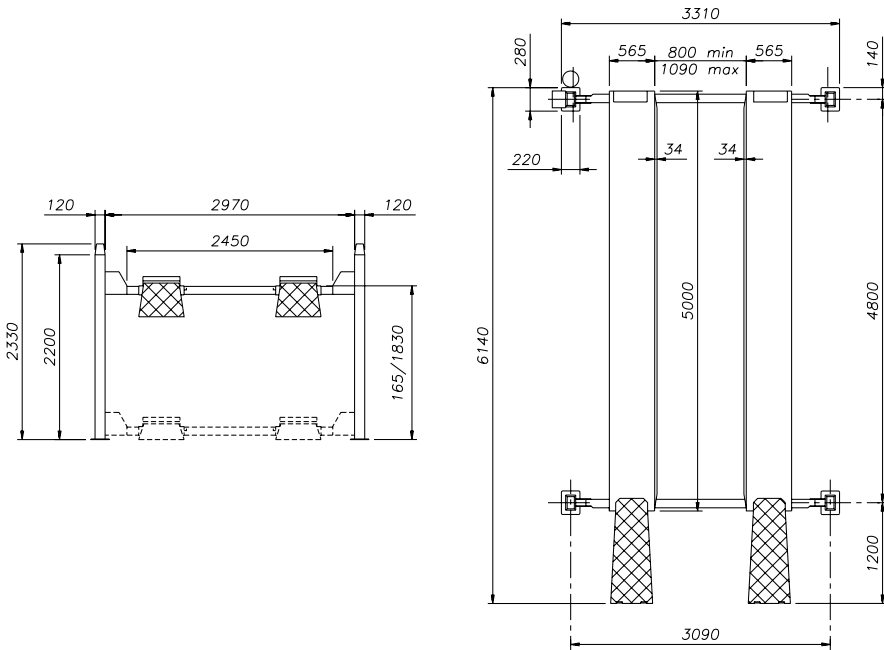

Dati tecnici	Technical data	Technische Eigenschaften	Caractéristiques techniques	Datos técnicos	
Portata	Capacity	Tragfähigkeit	Capacité	Capacidad	4.000 kg
Peso	Weight	Gewicht	Poids	Peso	1080 kg
Salita/Discesa	Lifting/descent	Hub/Senkzeit	Levage/descente	Subida/Bajada	30 s
Altezza di sollevamento	Lifting height	Hubhöhe	Hauteur de levage	Altura de elevación	1830 mm
Motore	Motor	Motorleistung	Puissance moteur	Motor	3,0 kW - 3 ph 230 400V/50 Hz

Funzionamento: Elettroidraulico • **Function: Electro-hydraulic** • Funktionsweise: Elektrohydraulisch • Fonctionnement: Electrohydraulique
 • Funcionamiento: Electro-hidráulico

Opzioni **Optionals** **Sonderzubehör** **Options** **Opcionales**



Traversa idraulica ausiliaria (vedere scheda specifica)
Hydraulic jacking beam (see relevant data sheet)
 Hydraulischer Radfreiheber (s. eigenes Datenblatt)
 Levage auxiliaire hydraulique (voir fiche technique)
 Elevador hidráulico auxiliar (ver ficha técnica)

Esecuzione con motore monofase • Kit illuminazione • Carter protezione centralina
Single-phase motor • Illumination kit • Cover for control unit
 Ausführung mit Einphasenmotor • Beleuchtungsset • Abdeckung für Hydraulikaggregat
 Moteur monophasé • Kit d'éclairage • Carter protection centrale hydraulique
 Motor monofásico • Kit de iluminación • Cubierta protectora para la centralita

The company reserves the right to introduce improvements in design or specification without prior notice







443

4,0 t

CE







-  Sollevatore elettroidraulico a 4 colonne super-ribassato
-  **Electro-hydraulic low profile 4 post lift**
-  Elektrohydraulische 4-Säulen-Hebebühne mit niedriger Auffahrhoehe
-  Pont élévateur électro-hydraulique à 4 colonnes surbaissé
-  Elevador electro-hidráulico de 4 columnas súper-bajo



* Optional

Carter protezione centralina
Cover for control unit
 Abdeckung für Hydraulikaggregat
 Carter protection centrale hydraulique
 Cubierta protectora para la centralita

-  Alta velocità di sollevamento • Sicurezza idraulica contro il sovraccarico • Valvola regolazione discesa • Segnale acustico ultimo tratto di discesa • Sicurezza idraulica in caso di rottura tubi idraulici • Comandi uomo presente 24 V • Sgancio automatico delle sicurezze per la discesa
-  High lifting and descent speed • Overload safety valve • Descent control valve • "Buzzer" on last portion of descent • Pipe burst safety valve • 24 V, low tension dead man controls •
-  Hohe Hub- und Senkgeschwindigkeit • Überdruckventil als Überlastsicherung • Senksteuerventil • Akustisches Signal im letzten Teil der Senkbewegung • Rohrbruch-Sicherheitsventil • 24 V-Totmannschaltung • Automatische Entriegelung der Lastsicherungshebel vor dem Absenken
-  Grande vitesse de levage et descente • Vanne de surpression contre surcharges • Vanne de réglage descente • Signal sonore sur la dernière partie de descente • Vanne d'arrêt en cas de rupture de la tuyauterie • Commandes de type homme mort à 24 V • Déclenchement automatique des crochets lors de la descente
-  Alta velocidad de elevación • Seguridad hidráulica contra la sobrecarga • Válvula de regulación del descenso • Señal acústica último tramo de descenso • Seguridad hidráulica en caso de rotura tubos hidráulicos • Mandos de hombre presente, 24V • Desenganche automático de las seguridades para el descenso

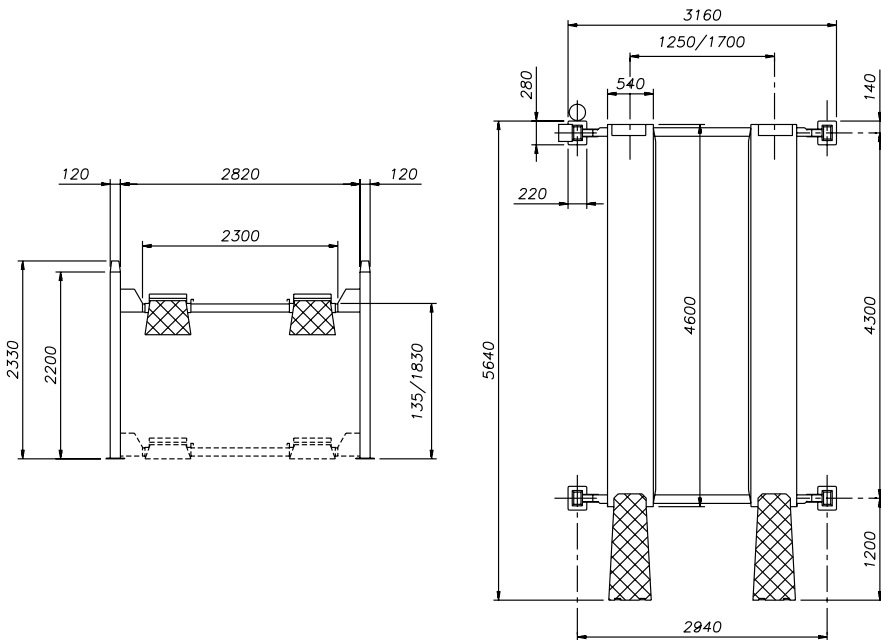
**Dati tecnici****Technical data****Technische Eigenschaften****Caractéristiques techniques****Datos técnicos**

Portata	Capacity	Tragfähigkeit	Capacité	Capacidad	4.000 kg
Peso	Weight	Gewicht	Poids	Peso	980 kg
Salita/Discesa	Lifting/descent	Hub/Senkzeit	Levage/descente	Subida/Bajada	30 s
Altezza di sollevamento	Lifting height	Hubhöhe	Hauteur de levage	Altura de elevación	1830 mm
Motore	Motor	Motorleistung	Puissance moteur	Motor	3,0 kW - 3 ph 230 400V/50 Hz

Funzionamento: Elettroidraulico • **Function: Electro-hydraulic** • Funktionsweise: Elektrohydraulisch • Fonctionnement: Electrohydraulique
• Funcionamiento: Electro-hidráulico

Opzioni**Optionals****Sonderzubehör****Options****Opcionales**

Traversa idraulica ausiliaria (vedere scheda specifica)
Hydraulic jacking beam (see relevant data sheet)
Hydraulischer Radfreiheber (s. eigenes Datenblatt)
Levage auxiliaire hydraulique (voir fiche technique)
Elevador hidráulico auxiliar (ver ficha técnica)

Esecuzione con motore monofase • Kit illuminazione • Carter protezione centralina • Disponibili versioni corrispondenti a normative specifiche (M.O.T.)

Single-phase motor • Illumination kit • Cover for control unit • Available with specific M.O.T. norms upon request

Ausführung mit Einphasenmotor • Beleuchtungsset • Abdeckung für Hydraulikaggregat • Es sind Ausführungen nach spezifischen Normen lieferbar (M.O.T.)

Moteur monophasé • Kit d'éclairage • Carter protection centrale hydraulique • On peut livrer versions correspondantes à normes spécifiques (M.O.T.)

Motor monofásico • Kit de iluminación • Cubierta protectora para la centralita • Disponibles versiones correspondientes a normas específicas (M.O.T.)

The company reserves the right to introduce improvements in design or specification without prior notice







450N/5

5,0 t

CE



-  Sollevatore elettroidraulico a 4 colonne
-  Electro-hydraulic 4 post lift
-  Elektrohydraulische 4-Säulenbühne
-  Pont élévateur Electrohydraulique 4 colonnes
-  Elevador electro-hidráulico de 4 columnas



* Optional

Carter protezione centralina
Cover for control unit
Abdeckung für Hydraulikaggregat
Carter protection centrale hydraulique
Cubierta protectora para la centralita

-  Sicurezza idraulica contro il sovraccarico • Valvola regolazione discesa • Stop automatico in discesa • Segnale acustico ultimo tratto di discesa • Sicurezza idraulica in caso di rottura tubi idraulici • Comandi uomo presente 24 V • Sgancio automatico delle sicurezze per la discesa
-  Overload safety valve • Descent control valve • Automatic descent stop • "Buzzer" on last portion of descent • Pipe burst safety valve • 24 V low tension dead man controls • Automatic release of safety locking devices
-  Überdruckventil als Überlastsicherung • Senksteuerventil • Automatische Senkstop-Steuerung • Akustisches Signal im letzten Teil der Senkbewegung • Rohrbruch-Sicherheitsventil • 24 V-Totmannschaltung • Automatische Entriegelung der Lastsicherungshebel vor dem Absenken
-  Vanne de surpression contre surcharges • Vanne de réglage descente • Arrêt automatique en descente • Signal sonore sur la dernière partie de descente • Vanne d'arrêt en cas de rupture de la tuyauterie • Commandes de type homme mort à 24 V • Déclanchement automatique des crochets lors de la descente
-  Seguridad hidráulica contra la sobrecarga • Válvula de regulación del descenso • Parada automática en descenso • Señal acústica último tramo de descenso • Seguridad hidráulica en caso de rotura tubos hidráulicos • Mandos de hombre presente, 24V • Desenganche automático de las seguridades para el descenso

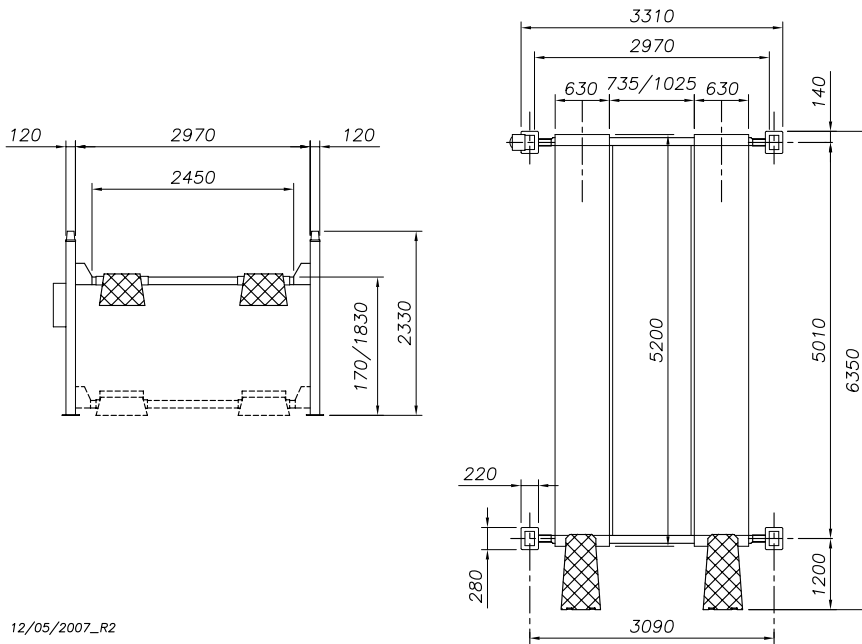

12/05/2007_R2

Dati tecnici	Technical data	Technische Eigenschaften	Caractéristiques techniques	Datos técnicos	
Portata	Capacity	Tragfähigkeit	Capacité	Capacidad	5.000 kg
Peso	Weight	Gewicht	Poids	Peso	1440 kg
Salita/Discesa	Lifting/descent	Hub/Senkzeit	Levage/descente	Subida/Bajada	50/45 s
Altezza di sollevamento	Lifting height	Hubhöhe	Hauteur de levage	Altura de elevación	1830 mm
Motore	Motor	Motorleistung	Puissance moteur	Motor	2,2kW - 3 ph 230 400V/50 Hz

Funzionamento: Elettroidraulico • **Function: Electro-hydraulic** • Funktionsweise: Elektrohydraulisch • Fonctionnement: Electrohydraulique
 • Funcionamiento: Electro-hidráulico

Opzioni **Optionals** **Sonderzubehör** **Options** **Opcionales**



Traversa idraulica ausiliaria (vedere scheda specifica)
Hydraulic jacking beam (see relevant data sheet)
 Hydraulischer Radfreiheber (s. eigenes Datenblatt)
 Levage auxiliaire hydraulique (voir fiche technique)
 Elevador hidráulico auxiliar (ver ficha técnica)

Esecuzione con motore monofase • Kit illuminazione • Carter protezione centralina
Single-phase motor • Illumination kit • Cover for control unit
 Ausführung mit Einphasenmotor • Beleuchtungsset • Abdeckung für Hydraulikaggregat
 Moteur monophasé • Kit d'éclairage • Carter protection centrale hydraulique
 Motor monofásico • Kit de iluminación • Cubierta protectora para la centralita

The company reserves the right to introduce improvements in design or specification without prior notice



450LT

5,0 t

CE



 Sollevatore elettroidraulico a 4 colonne con sollevatore ausiliario incorporato

 Electro-hydraulic 4 post lift with built in lifting table

 Elektrohydraulische 4-Säulen-Hebebühne mit eingebautem Radfreiheber

 Pont élévateur électro-hydraulique à 4 colonnes avec levage auxiliaire incorporé

 Elevador electro-hidráulico de 4 columnas con Elevador auxiliar incorporado



*

Carter protezione centralina

Cover for control unit

Abdeckung für Hydraulikaggregat

Carter protection centrale hydraulique

Cubierta protectora para la centralita

Sollevatore ausiliario da 4,0 t

Lifting table with 4,0 t capacity

Radfreiheber 4,0 t Tragkraft

Levage auxiliaire capacité 4,0 t

Elevador auxiliario

* Optional

 Sicurezza idraulica contro il sovraccarico • Valvola regolazione discesa • Stop automatico in discesa • Segnale acustico ultimo tratto di discesa • Sicurezza idraulica in caso di rottura tubi idraulici • Comandi uomo presente 24 V • Sgancio automatico delle sicurezze per la discesa

 **Overload safety valve • Descent control valve • Automatic descent stop • "Buzzer" on last portion of descent • Pipe burst safety valve • 24 V, low tension dead man controls • Automatic release of safety locking devices**

 Überdruckventil als Überlastsicherung • Senksteuerventil • Automatische Senkstop-Steuerung • Akustisches Signal im letzten Teil der Senkbewegung • Rohrbruch-Sicherheitsventil • 24 V-Totmannschaltung • Automatische Entriegelung der Lastsicherungshebel vor dem Absenken

 Vanne de surpression contre surcharges • Vanne de réglage descente • Arrêt automatique en descente • Signal sonore sur la dernière partie de descente • Vanne d'arrêt en cas de rupture de la tuyauterie • Commandes de type homme mort à 24 V • Déclanchement automatique des crochets lors de la descente

 Seguridad hidráulica contra la sobrecarga • Válvula de regulación del descenso • Parada automática en descenso • Señal acústica último tramo de descenso • Seguridad hidráulica en caso de rotura tubos hidráulicos • Mandos de hombre presente, 24V • Desenganche automático de las seguridades para el descenso

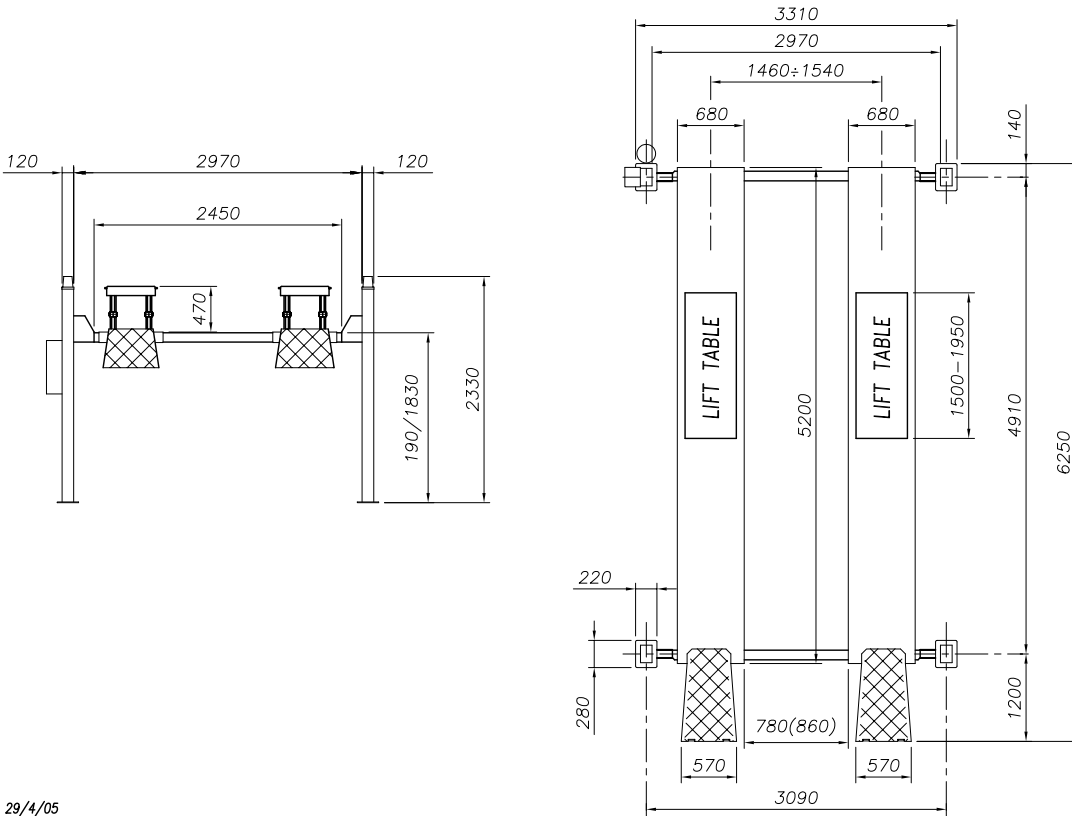

29/4/05



Dati tecnici	Technical data	Technische Eigenschaften	Caractéristiques techniques	Datos técnicos	
Portata	Capacity	Tragfähigkeit	Capacité	Capacidad	5.000 kg
Peso	Weight	Gewicht	Poids	Peso	1800 kg
Salita/Discesa	Lifting/descent	Hub/Senkzeit	Levage/descente	Subida/Bajada	50/45 s
Altezza di sollevamento	Lifting height	Hubhöhe	Hauteur de levage	Altura de elevación	1830 mm
Motore	Motor	Motorleistung	Puissance moteur	Motor	3,0 kW - 3 ph 230 400V/50 Hz

* Sollevatore ausiliario da 4,0 t / * **Lifting table with 4,0 t capacity** / * Radfreiheber 4,0 t Tragkraft / * Levage auxiliaire capacité 4,0 t / * Elevador auxiliar con una capacidad de 4,0 t

Funzionamento: Elettroidraulico • **Function: Electro-hydraulic** • Funktionsweise: Elektrohydraulisch • Fonctionnement: Electrohydraulique • Funcionamiento: Electro-hidráulico



Esecuzione con motore monofase • Kit illuminazione • Carter protezione centralina
Single-phase motor • Illumination kit • Cover for control unit
 Ausführung mit Einphasenmotor • Beleuchtungsset • Abdeckung für Hydraulikaggregat
 Moteur monophasé • Kit d'éclairage • Carter protection centrale hydraulique
 Motor monofásico • Kit de iluminación • Cubierta protectora para la centralita

The company reserves the right to introduce improvements in design or specification without prior notice







460





6,0 t

CE



-  Sollevatore elettro-idraulico a 4 colonne
-  **Electro-hydraulic 4 post lift**
-  Elektrohydraulische 4-Säulenbühne
-  Pont élévateur électro-hydraulique 4 colonnes
-  Elevador electro-hidráulico de 4 columnas



-  Sicurezza in caso di rottura fune • Sicurezza idraulica in caso di sovraccarico • Valvola di controllo velocità discesa • Valvola sicurezza in caso di rottura tubo idraulico • Comandi uomo presente 24V • Comando sgancio elettrico • Comando automatico di discesa • Insonorizzazione sicurezze • Avvisatore acustico fase finale discesa
-  Safety device in case of cable breakage • Overload safety-valve • Descent control valve • Pipe burst safety valve • 24V, low tension dead man controls • Electrical controlled fall safety • Automatic release of safety locking devices • Automatic descent control • Soundproof safety devices • Buzzer on last portion of descent
-  Seilbruchsicherung • Überdrucksicherung • Sinkgeschwindigkeits-Regelventil • Rohrbruch-Sicherheitsventil • Totmann-Schaltung 24V • Elektrische Entriegelung der Sicherheitsrasten • Autom. Sicherheitsstop • Schalldaempfung Sicherheitshebel • Akustisches Signal Endphase Abstieg
-  Sécurité en cas de rupture d'un cable • Sécurité hydraulique en cas de surcharge • Vanne de contrôle descente • Vanne de sécurité en cas de rupture de tuyauterie • Commande de type "homme mort" 24V • Déverrouillage à commande électrique • Commande automatique de descente • Insonorisation sécurité • Signal sonore sur la dernière partie de la descente
-  Seguridad en caso de rotura cable • Seguridad hidráulica en caso de sobrecarga • Válvula de control velocidad descenso • Válvula de seguridad en caso de rotura del tubo hidráulico • Mandos de "hombre presente", 24V • Mando de desenganche eléctrico • Mando automático de descenso • Insonorización seguridades • Aviso acústico fase final de bajada

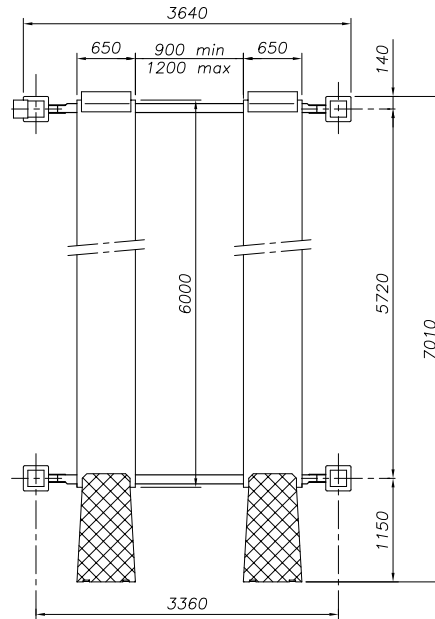
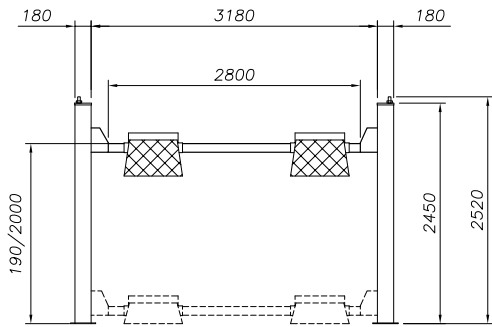

Dati tecnici	Technical data	Technische Eigenschaften	Caractéristiques techniques	Datos técnicos	
Portata	Capacity	Tragfähigkeit	Capacité	Capacidad	6.000 kg
Peso	Weight	Gewicht	Poids	Peso	1340 kg
Salita/Discesa	Lifting/descent	Hub/Senkzeit	Levage/descente	Subida/Bajada	55 s
Altezza di sollevamento	Lifting height	Hubhöhe	Hauteur de levage	Altura de elevación	2000 mm
Motore	Motor	Motorleistung	Puissance moteur	Motor	3,0 kW - 3 ph 230 400V/50 Hz

Funzionamento: Elettroidraulico • **Function: Electro-hydraulic** • Funktionsweise: Elektrohydraulisch • Fonctionnement: Electrohydraulique
 • Funcionamiento: Electro-hidráulico

Opzioni **Optionals** **Sonderzubehör** **Options** **Opcionales**



Traversa idraulica ausiliaria (vedere scheda specifica)
Hydraulic jacking beam (see relevant data sheet)
 Hydraulischer Radfreiheber (s. eigenes Datenblatt)
 Levage auxiliaire hydraulique (voir fiche technique)
 Elevador hidráulico auxiliar (ver ficha técnica)

Esecuzione con motore monofase • Kit illuminazione • Carter protezione centralina
Single-phase motor • Illumination kit • Cover for control unit
 Ausführung mit Einphasenmotor • Beleuchtungsset • Abdeckung für Hydraulikaggregat
 Moteur monophasé • Kit d'éclairage • Carter protection centrale hydraulique
 Motor monofásico • Kit de iluminación • Cubierta protectora para la centralita







480





8,0 t

CE



-  Sollevatore elettro-idraulico a 4 colonne
-  **Electro-hydraulic 4 post lift**
-  Elektrohydraulische 4-Säulenbühne
-  Pont élévateur électro-hydraulique 4 colonnes
-  Elevador electro-hidráulico de 4 columnas



-  Sicurezza in caso di rottura fune • Sicurezza idraulica in caso di sovraccarico • Valvola di controllo velocità discesa • Valvola sicurezza in caso di rottura tubo idraulico • Comandi uomo presente 24V • Comando sgancio elettrico • Comando automatico di discesa • Insonorizzazione sicurezze • Avvisatore acustico fase finale discesa
-  Safety device in case of cable breakage • Overload safety-valve • Descent control valve • Safety-valve in case of sudden loss of pressure • "Dead man" controls 24V • Automatic release of safety locking devices • Automatic descent control • Soundproof safety devices • Buzzer on last portion of descent
-  Seilbruchsicherung • Überdrucksicherung • Sinkgeschwindigkeits-Regelventil • Rohrbruch-Sicherheitsventil • Totmann-Schaltung 24V • Elektrische Entriegelung der Sicherheitsrasten • Autom. Sicherheitsstop • Schalldaempfung Sicherheitshebel • Akustisches Signal Endphase Abstieg
-  Sécurité en cas de rupture d'un cable • Sécurité hydraulique en cas de surcharge • Vanne de contrôle descente • Vanne de sécurité en cas de rupture de tuyauterie • Commande de type "homme mort" 24V • Déverrouillage à commande électrique • Commande automatique de descente • Insonorisation sécurité • Signal sonore sur la dernière partie de la descente
-  Seguridad en caso de rotura cable • Seguridad hidráulica en caso de sobrecarga • Válvula de control velocidad descenso • Válvula de seguridad en caso de rotura del tubo hidráulico • Mandos de "hombre presente", 24V • Mando de desenganche eléctrico • Mando automático de descenso • Insonorización seguridades • Aviso acústico fase final de bajada

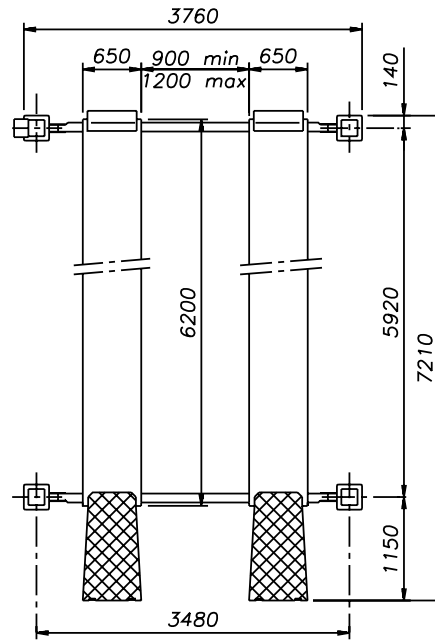
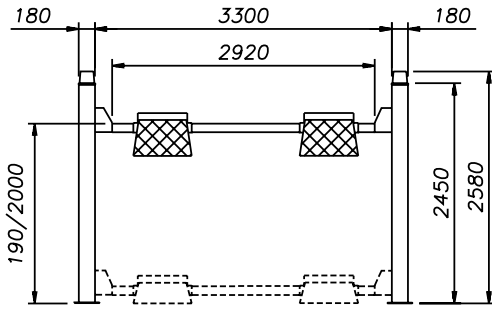

Dati tecnici	Technical data	Technische Eigenschaften	Caractéristiques techniques	Datos técnicos	
Portata	Capacity	Tragfähigkeit	Capacité	Capacidad	8.000 kg
Peso	Weight	Gewicht	Poids	Peso	1900 kg
Salita/Discesa	Lifting/descent	Hub/Senkzeit	Levage/descente	Subida/Bajada	55 s
Altezza di sollevamento	Lifting height	Hubhöhe	Hauteur de levage	Altura de elevación	2000 mm
Motore	Motor	Motorleistung	Puissance moteur	Motor	3,0 kW - 3 ph 230 400V/50 Hz

Funzionamento: Elettroidraulico • **Function: Electro-hydraulic** • Funktionsweise: Elektrohydraulisch • Fonctionnement: Electrohydraulique
 • Funcionamiento: Electro-hidráulico

Opzioni **Optionals** **Sonderzubehör** **Options** **Opcionales**



Traversa idraulica ausiliaria (vedere scheda specifica)
Hydraulic jacking beam (see relevant data sheet)
 Hydraulischer Radfreiheber (s. eigenes Datenblatt)
 Levage auxiliaire hydraulique (voir fiche technique)
 Elevador hidráulico auxiliar (ver ficha técnica)

Esecuzione con motore monofase • Kit illuminazione • Carter protezione centralina
Single-phase motor • Illumination kit • Cover for control unit
 Ausführung mit Einphasenmotor • Beleuchtungsset • Abdeckung für Hydraulikaggregat
 Moteur monophasé • Kit d'éclairage • Carter protection centrale hydraulique
 Motor monofásico • Kit de iluminación • Cubierta protectora para la centralita

The company reserves the right to introduce improvements in design or specification without prior notice







412





12,0 t

CE



-  Sollevatore elettro-idraulico a 4 colonne
-  **Electro-hydraulic 4 post lift**
-  Elektrohydraulische 4-Säulenbühne
-  Pont élévateur électro-hydraulique 4 colonnes
-  Elevador electro-hidráulico de 4 columnas

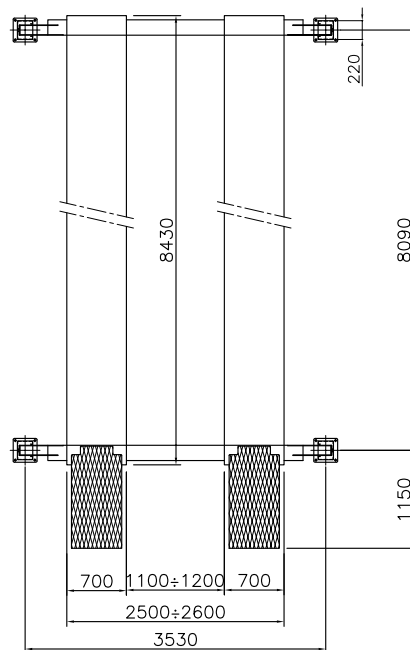
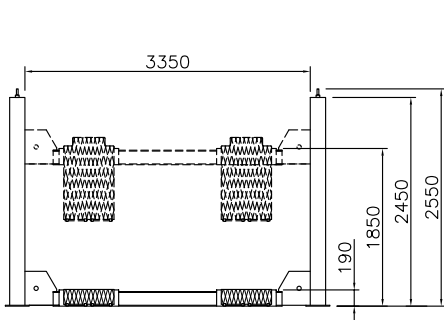

-  Sicurezza in caso di rottura fune • Sicurezza idraulica in caso di sovraccarico • Valvola di controllo velocità discesa • Valvola sicurezza in caso di rottura tubo idraulico • Comandi uomo presente 24V • Comando sgancio elettrico • Insonorizzazione sicurezze • Avvisatore acustico fase finale discesa
-  Safety device in case of cable breakage • Overload safety-valve • Descent control valve • Safety-valve in case of sudden loss of pressure • "Dead man" controls 24V • Automatic release of safety locking devices • Soundproof safety devices • Buzzer on last portion of descent
-  Seilbruchsicherung • Überdrucksicherung • Sinkgeschwindigkeits-Regelventil • Rohrbruch-Sicherheitsventil • Totmann-Schaltung 24V • Elektrische Entriegelung der Sicherheitsrasten • Schalldaempfung Sicherheitshebel • Akustisches Signal Endphase Abstieg
-  Sécurité en cas de rupture d'un cable • Sécurité hydraulique en cas de surcharge • Vanne de contrôle descente • Vanne de sécurité en cas de rupture de tuyauterie • Commande de type "homme mort" 24V • Déverrouillage à commande électrique • Insonorisation sécurité • Signal sonore sur la dernière partie de la descente
-  Seguridad en caso de rotura cable • Seguridad hidráulica en caso de sobrecarga • Válvula de control velocidad descenso • Válvula de seguridad en caso de rotura del tubo hidráulico • Mandos de "hombre presente", 24V • Mando de desenganche eléctrico • Insonorización seguridades • Aviso acústico fase final de bajada

**Dati tecnici****Technical data****Technische Eigenschaften****Caractéristiques techniques****Datos técnicos**

Portata	Capacity	Tragfähigkeit	Capacité	Capacidad	12.000 kg
Peso	Weight	Gewicht	Poids	Peso	3000 kg
Salita/Discesa	Lifting/descent	Hub/Senkzeit	Levage/descente	Subida/Bajada	55 s
Altezza di sollevamento	Lifting height	Hubhöhe	Hauteur de levage	Altura de elevación	1850 mm
Motore	Motor	Motorleistung	Puissance moteur	Motor	3,0 kW - 3 ph 230 400V/50 Hz

Funzionamento: Elettroidraulico • **Function: Electro-hydraulic** • Funktionsweise: Elektrohydraulisch • Fonctionnement: Electrohydraulique
• Funcionamiento: Electro-hidráulico

Opzioni**Optionals****Sonderzubehör****Options****Opcionales**

Traversa idraulica ausiliaria (vedere scheda specifica)
Hydraulic jacking beam (see relevant data sheet)
Hydraulischer Radfreiheber (s. eigenes Datenblatt)
Levage auxiliaire hydraulique (voir fiche technique)
Elevador hidráulico auxiliar (ver ficha técnica)

Esecuzione con motore monofase • Kit illuminazione • Carter protezione centralina

Single-phase motor • Illumination kit • Cover for control unit

Ausführung mit Einphasenmotor • Beleuchtungsset • Abdeckung für Hydraulikaggregat

Moteur monophasé • Kit d'éclairage • Carter protection centrale hydraulique

Motor monofásico • Kit de iluminación • Cubierta protectora para la centralita







430

3,5 t

CE



-  Sollevatore elettroidraulico a 4 colonne con incavi anteriori per allineamento ruote
-  **Electro-hydraulic 4 post lift with front recesses for wheel alignment**
-  Elektrohydraulische 4-Säulen-Hebebühne mit vorderen Aussparungen für die Vorderachsvermessung
-  Pont élévateur électro-hydraulique à 4 colonnes avec encastresments avant pour géométrie
-  Elevador electro-hidráulico de 4 columnas con asientos delanteros para alineación de las ruedas



-  Sicurezza idraulica contro il sovraccarico • Valvola regolazione discesa • Segnale acustico ultimo tratto di discesa • Sicurezza idraulica in caso di rottura tubi idraulici • Comandi uomo presente 24 V • Sgancio elettrico del sistema di sicurezza meccanico
-  **Overload safety valve • Descent control valve • "Buzzer" on last portion of descent • Pipe burst safety valve • 24 V, low tension dead man controls • Automatic release of safety locking devices**
-  Überdruckventil gegen Überlastung • Senksteuerventil • Akustisches Signal im letzten Teil der Senkbewegung • Rohrbruchsicherung • 24 V-Totmann-Steuerung • Elektrische Entriegelung der mechanischen Lastsicherung
-  Vanne de surpression contre surcharges • Vanne de réglage descente • Signal sonore sur la dernière partie de descente • Vanne d'arrêt en cas de rupture de la tuyauterie • Commandes de type homme mort à 24 V • Déverrouillage électrique du système de sécurité mécanique
-  Seguridad hidráulica contra la sobrecarga • Válvula de regulación del descenso • Señal acústica último tramo de descenso • Seguridad hidráulica en caso de rotura tubos hidráulicos • Mandos de hombre presente, 24V • Desenganche eléctrico del sistema de seguridad mecánico

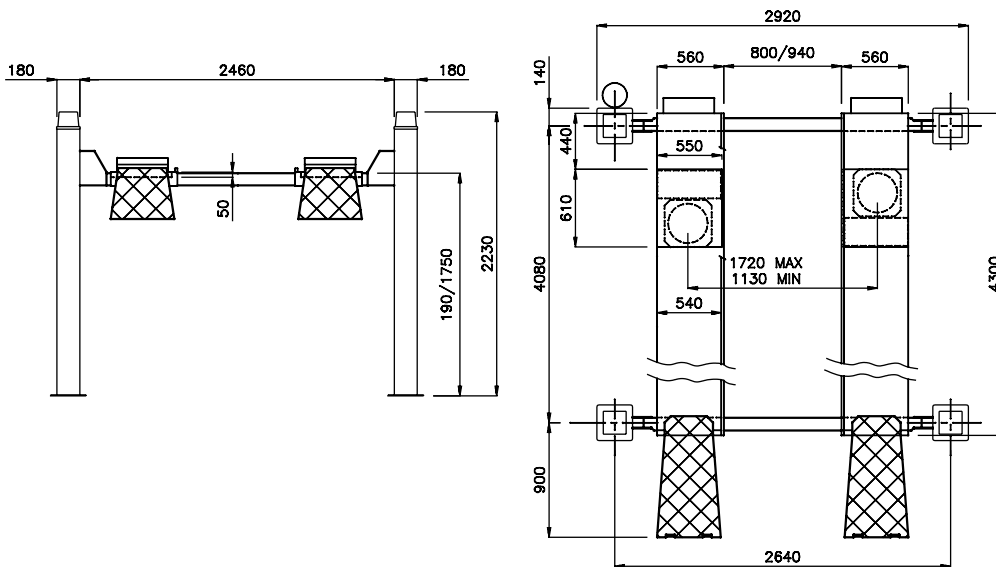

Dati tecnici	Technical data	Technische Eigenschaften	Caractéristiques techniques	Datos técnicos	
Portata	Capacity	Tragfähigkeit	Capacité	Capacidad	3.500 kg
Peso	Weight	Gewicht	Poids	Peso	830 kg
Salita/Discesa	Lifting/descent	Hub/Senkzeit	Levage/descente	Subida/Bajada	50/45 s
Altezza di sollevamento	Lifting height	Hubhöhe	Hauteur de levage	Altura de elevación	1750 mm
Motore	Motor	Motorleistung	Puissance moteur	Motor	2,2 kW - 3 ph 230 400V/50 Hz

Funzionamento: Elettroidraulico • **Function: Electro-hydraulic** • Funktionsweise: Elektrohydraulisch • Fonctionnement: Electrohydraulique
• Funcionamiento: Electro-hidráulico

Opzioni

Optionals

Sonderzubehör

Options

Opcionales



Traversa idraulica ausiliaria (vedere scheda specifica)
Hydraulic jacking beam (see relevant data sheet)
Hydraulischer Radfreiheber (s. eigenes Datenblatt)
Levage auxiliaire hydraulique (voir fiche technique)
Elevador hidráulico auxiliar (ver ficha técnica)



Piatti Rotanti
Radius plates
Drehplatten
Plaques pivotantes
Platos giratorios

Esecuzione con motore monofase • Kit illuminazione • Coperchi per incavi anteriori • Carter protezione centralina • Disponibili versioni corrispondenti a normative specifiche (M.O.T.)

Single-phase motor • Illumination kit • Covers for front recesses • Cover for control unit • Versions according to specific rules available (M.O.T.)

Ausführung mit Einphasenmotor • Beleuchtungsset • Abdeckbleche für Frontaussparungen • Abdeckung für Hydraulikaggregat • Es sind Ausführungen nach spezifischen Normen lieferbar (M.O.T.)

Moteur monophasé • Kit d'éclairage • Complements pour encastresments avant • Carter protection centrale hydraulique • On peut livrer versions correspondantes à normes spécifiques (M.O.T.)

Motor monofásico • Kit de iluminación • Tapa para asientos delanteros • Cubierta protectora para la centralita • Disponibles versiones correspondientes a normas específicas (M.O.T.)

The company reserves the right to introduce improvements in design or specification without prior notice







430 BL





4,0 t

CE



-  Sollevatore elettroidraulico a 4 colonne con incavi anteriori e piastre oscillanti posteriori per allineamento ruote
-  Electro-hydraulic 4 post lift with front recesses and rear slip plates for wheel alignment
-  Elektrohydraulische 4-Säulen-Hebebühne mit vorderen Aussparungen und hinteren Schiebepplatten für die Achsvermessung
-  Pont élévateur électro-hydraulique à 4 colonnes avec encastremets avant et plaques arrière pour géométrie
-  Elevador electro-hidráulico de 4 columnas con asientos delanteros y platos oscilantes traseros para alineación de las ruedas



-  Sicurezza idraulica contro il sovraccarico • Valvola regolazione discesa • Segnale acustico ultimo tratto di discesa • Sicurezza idraulica in caso di rottura tubi idraulici • Comandi uomo presente 24 V • Sgancio elettrico del sistema di sicurezza meccanico
-  **Overload safety valve • Descent control valve • "Buzzer" on last portion of descent • Pipe burst safety valve • 24 V, low tension dead man controls • Automatic release of safety locking devices**
-  Überdruckventil als Überlastsicherung • Senksteuerventil • Akustisches Signal im letzten Teil der Senkbewegung • Rohrbruch-Sicherheitsventil • 24 V-Totmannschaltung • Elektrische Entriegelung der mechanischen Lastsicherung
-  Vanne de surpression contre surcharges • Vanne de réglage descente • Signal sonore sur la dernière partie de descente • Vanne d'arrêt en cas de rupture de la tuyauterie • Commandes de type homme mort à 24 V • Déverrouillage électrique du système de sécurité mécanique
-  Seguridad hidráulica contra la sobrecarga • Válvula de regulación del descenso • Señal acústica último tramo de descenso • Seguridad hidráulica en caso de rotura tubos hidráulicos • Mandos de hombre presente, 24V • Desenganche eléctrico del sistema de seguridad mecánico

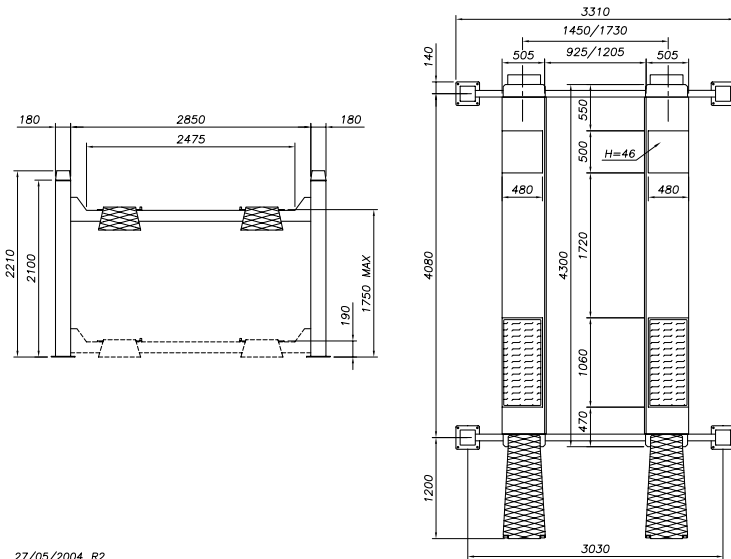

27/05/2004_R2

Dati tecnici	Technical data	Technische Eigenschaften	Caractéristiques techniques	Datos técnicos	
Portata	Capacity	Tragfähigkeit	Capacité	Capacidad	4.000 kg
Peso	Weight	Gewicht	Poids	Peso	910 kg
Salita/Discesa	Lifting/descent	Hub/Senkzeit	Levage/descente	Subida/Bajada	50/45 s
Altezza di sollevamento	Lifting height	Hubhöhe	Hauteur de levage	Altura de elevación	1750 mm
Motore	Motor	Motorleistung	Puissance moteur	Motor	2,2 kW - 3 ph 230 400V/50 Hz

Funzionamento: Elettroidraulico • **Function: Electro-hydraulic** • Funktionsweise: Elektrohydraulisch • Fonctionnement: Electrohydraulique
 • Funcionamiento: Electro-hidráulico

Opzioni **Optionals** **Sonderzubehör** **Options** **Opcionales**



Traversa idraulica ausiliaria (vedere scheda specifica)
 Hydraulic jacking beam (see relevant data sheet)
 Hydraulischer Radfreiheber (s. eigenes Datenblatt)
 Levage auxiliaire hydraulique (voir fiche technique)
 Elevador hidráulico auxiliar (ver ficha técnica)



Piatti Rotanti
 Radius plates
 Drehplatten
 Plaques pivotantes
 Platos giratorios

Esecuzione con motore monofase • Kit illuminazione • Coperchi per incavi anteriori • Carter protezione centralina
 Single-phase motor • Illumination kit • Cover for control unit • Cover for control unit
 Ausführung mit Einphasenmotor • Beleuchtungsset • Abdeckung für Hydraulikaggregat • Abdeckung für Hydraulikaggregat
 Moteur monophasé • Kit d'éclairage • Carter protection centrale hydraulique • Carter protection centrale hydraulique
 Motor monofásico • Kit de iluminación • Cubierta protectora para la centralita • Cubierta protectora para la centralita

The company reserves the right to introduce improvements in design or specification without prior notice







443 ATLT

4,0 t





CE



-  Sollevatore elettroidraulico a 4 colonne con incavi anteriori e piastre oscillanti posteriori per allineamento ruote e sollevatore ausiliario incorporato
-  **Electro-hydraulic 4 post lift with front recesses and rear slipping plates for wheel alignment and built in lifting table**
-  Elektrohydraulische 4-Säulen-Hebebühne mit vorderen Aussparungen und hinteren Schiebleplatten für die Achsvermessung und eingebautem Radfreiheber
-  Pont élévateur électro-hydraulique à 4 colonnes avec encastremets avant et plaques arrière pour géométrie et levage auxiliaire incorporé
-  Elevador electro-hidráulico de 4 columnas con asientos delanteros y platos oscilantes traseros para alineación de las ruedas y Elevador auxiliar incorporado



Sollevatore ausiliario da 3,5 t
Lifting table with 3,5 t capacity
 Radfreiheber 3,5 t Tragkraft
 Levage auxiliaire capacité 3,5 t
 Elevador auxiliar con capacidad de 3,5 t

-  Super - ribassato • Alta velocità di sollevamento • Sicurezza in caso di rottura fune • Sicurezza idraulica in caso di sovraccarico • Valvola di controllo velocità di discesa • Valvola sicurezza in caso di rottura tubo idraulico • Comando uomo presente 24 Volt • Comando automatico di discesa • Insonorizzazione sicurezze • Segnale acustico ultimo tratto di discesa
-  **Low profile • High lifting and descent speed • Safety device in case of cable breakage • Overload safety-device • Descent control valve • Safety-valve in case of sudden loss of pressure • Dead man controls 24V • Automatic descent control • Soundproof safety devices • "Buzzer" on last portion of descent**
-  Niedrige Auffahrhöhe • Hohe Hub- und Senkgeschwindigkeit • Seilbruchsicherung • Rohrbruchsicherung • Senkregelventil • Hydraulische Überlastsicherung • 24 V- Totmannschaltung • Autom. Senksteuerung • Schallgedämpfte Sicherheitsklinken • Akustisches Signal im letzten Teil der Senkbewegung
-  Surbaissé • Grande vitesse de levage et descente • Sécurité en cas de rupture du câble • Sécurité hydraulique en cas de surcharge • Vanne de contrôle descente • Vanne de sécurité hydraulique en cas de rupture de tuyauterie • Commande de type homme mort 24V • Commande automatique de descente • Insonorisation des sécurités • Signal sonore sur la dernière partie de descente
-  Súper-bajo • Alta velocidad de elevación • Seguridad en caso de rotura cable de acero • Seguridad hidráulica contra la sobrecarga • Válvula de control velocidad descenso • Válvula de seguridad en caso de rotura del tubo hidráulico • Mandos de hombre presente, 24V • Mando automático de descenso • Insonorización de seguridades • Señal acústica último tramo de descenso

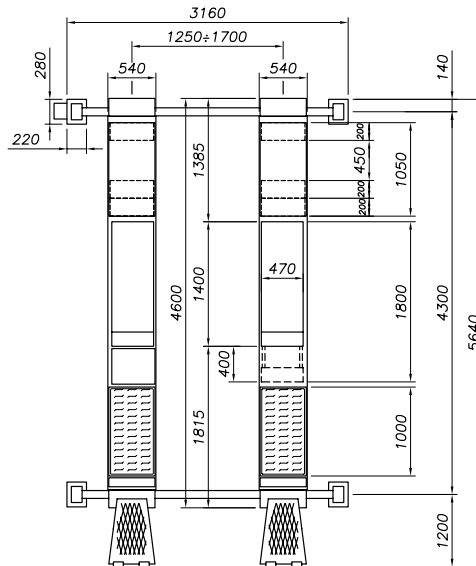
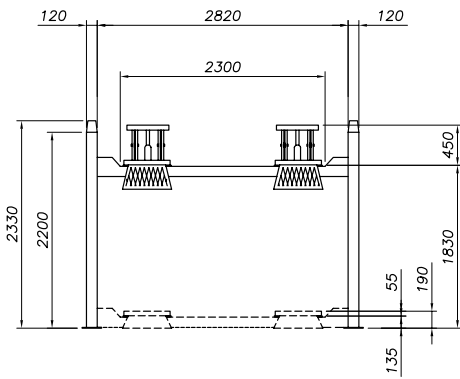

Dati tecnici	Technical data	Technische Eigenschaften	Caractéristiques techniques	Datos técnicos	
Portata	Capacity	Tragfähigkeit	Capacité	Capacidad	4.000 kg
Peso	Weight	Gewicht	Poids	Peso	1200 kg
Salita/Discesa	Lifting/descent	Hub/Senkzeit	Levage/descente	Subida/Bajada	30 s
Altezza di sollevamento	Lifting height	Hubhöhe	Hauteur de levage	Altura de elevación	1830+450 mm
Motore	Motor	Motorleistung	Puissance moteur	Motor	3,0 kW - 3 ph 230 400V/50 Hz

Funzionamento: Elettroidraulico • **Function: Electro-hydraulic** • Funktionsweise: Elektrohydraulisch • Fonctionnement: Electrohydraulique • Funcionamiento: Electro-hidráulico

Sollevatore ausiliario da 3,5 t • **Lifting table with 3,5 t capacity** • Radfreiheber 3,5 t Tragkraft • Levage auxiliaire capacité 3,5 t • Elevador auxiliar con capacidad de 3,5 t

Opzioni **Optionals** **Sonderzubehör** **Options** **Opcionales**



Piatti Rotanti
Radius plates
Drehplatten
Plaques pivotantes
Platos giratorios

Esecuzione con motore monofase • Kit illuminazione • Carter protezione centralina
Single-phase motor • Illumination kit • Cover for control unit
Ausführung mit Einphasenmotor • Beleuchtungsset • Abdeckung für Hydraulikaggregat
Moteur monophasé • Kit d'éclairage • Carter protection centrale hydraulique
Motor monofásico • Kit de iluminación • Cubierta protectora para la centralita







450 AT





4,0 t

CE



-  Sollevatore elettroidraulico a 4 colonne con incavi anteriori e piastre oscillanti posteriori per allineamento ruote
-  **Electro-hydraulic 4 post lift with front recesses and rear slipping plates for wheel alignment**
-  Elektrohydraulische 4-Säulen-Hebebühne mit vorderen Aussparungen und hinteren Schiebepplatten für die Achsvermessung
-  Pont élévateur électro-hydraulique à 4 colonnes avec encastremets avant et plaques arrière pour géométrie
-  Elevador electro-hidráulico de 4 columnas con asientos delanteros y platos oscilantes traseros para alineación de las ruedas



-  Sicurezza idraulica contro il sovraccarico • Valvola regolazione discesa • Segnale acustico ultimo tratto di discesa • Sicurezza idraulica in caso di rottura tubi idraulici • Comandi uomo presente 24 V • Sgancio elettrico del sistema di sicurezza meccanico
-  **Overload safety valve • Descent control valve • 'Buzzer' on last portion of descent • Pipe burst safety valve • 24 V, low tension dead man controls • Automatic release of safety locking devices**
-  Überdruckventil als Überlastsicherung • Senksteuerventil • Akustisches Signal im letzten Teil der Senkbewegung • Rohrbruch-Sicherheitsventil • 24 V-Totmannschaltung • Elektrische Entriegelung der mechanischen Lastsicherung
-  Vanne de surpression contre surcharges • Vanne de réglage descente • Signal sonore sur la dernière partie de descente • Vanne d'arrêt en cas de rupture de la tuyauterie • Commandes de type homme mort à 24 V • Déverrouillage électrique du système de sécurité mécanique
-  Seguridad hidráulica contra la sobrecarga • Válvula de regulación del descenso • Señal acústica último tramo de descenso • Seguridad hidráulica en caso de rotura de los tubos hidráulicos • Mandos de hombre presente, 24V • Desenganche eléctrico del sistema de seguridad mecánico

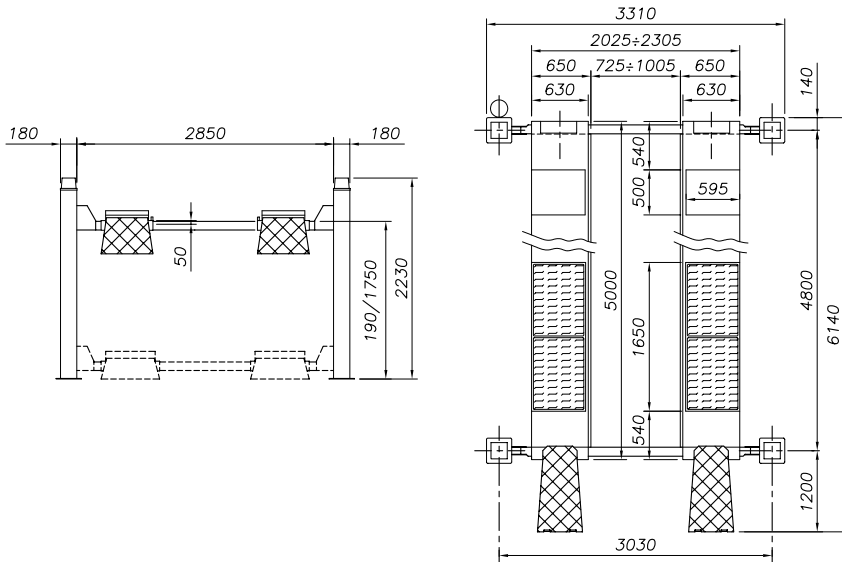

Dati tecnici	Technical data	Technische Eigenschaften	Caractéristiques techniques	Datos técnicos	
Portata	Capacity	Tragfähigkeit	Capacité	Capacidad	4.000 kg
Peso	Weight	Gewicht	Poids	Peso	1300 kg
Salita/Discesa	Lifting/descent	Hub/Senkzeit	Levage/descente	Subida/Bajada	50/45 s
Altezza di sollevamento	Lifting height	Hubhöhe	Hauteur de levage	Altura de elevación	1750 mm
Motore	Motor	Motorleistung	Puissance moteur	Motor	2,2 kW - 3 ph 230 400V/50 Hz

Funzionamento: Elettroidraulico • **Function: Electro-hydraulic** • Funktionsweise: Elektrohydraulisch • Fonctionnement: Electrohydraulique • Funcionamiento: Electro-hidráulico

Opzioni **Optionals** **Sonderzubehör** **Options** **Opcionales**



Traversa idraulica ausiliaria (vedere scheda specifica)
Hydraulic jacking beam (see relevant data sheet)
 Hydraulischer Radfreiheber (s. eigenes Datenblatt)
 Levage auxiliaire hydraulique (voir fiche technique)
 Elevador hidráulico auxiliar (ver ficha técnica)



Piatti Rotanti
Radius plates
 Drehplatten
 Plaques pivotantes
 Platos giratorios

Esecuzione con motore monofase • Kit illuminazione • Disponibili versioni corrispondenti a normative specifiche (M.O.T.) • Carter protezione centralina
Single-phase motor • Illumination kit • Versions according to specific rules available (M.O.T.) • Cover for control unit
 Ausführung mit Einphasenmotor • Beleuchtungsset • Es sind Ausführungen nach spezifischen Normen lieferbar (M.O.T.) • Abdeckung für Hydraulikaggregat
 Moteur monophasé • Kit d'éclairage • On peut livrer versions correspondantes à normes spécifiques (M.O.T.) • Carter protection centrale hydraulique
 Motor monofásico • Kit de iluminación • Disponibles versiones correspondientes a normas específicas (M.O.T.) • Cubierta protectora para la centralita

The company reserves the right to introduce improvements in design or specification without prior notice







450/3D

5,0 t

CE



-  Sollevatore elettroidraulico a 4 colonne alta velocità con pedane strette per assetto ruote 3D
-  **Electro-hydraulic high speed 4 post-lift with narrow platforms for 3D-wheel-alignment**
-  Elektrohydraulische 4-Säulen Hebebühne, mit hoher Hubgeschwindigkeit, schmale Fahrschienen für 3D-Achsvermessung
-  Pont élévateur Electrohydraulique. 4 colonnes grande vitesse avec chemins de roulement étroits pour contrôle train avant 3D
-  Elevador electro-hidráulico de 4 columnas alta velocidad con plataformas estrechas para alineación 3D de las ruedas



-  Sicurezza in caso di rottura fune • Sicurezza idraulica contro il sovraccarico • Valvola regolazione discesa • Sicurezza idraulica in caso di rottura tubi idraulici • Comandi uomo presente 24 V • Sgancio automatico delle sicurezze per la discesa • Insonorizzazione sicurezze • Valvola manuale controllo discesa • Massima altezza pedane 1950mm
-  **Safety device in case of cable breakage • Overload safety valve • Descent control valve • Pipe burst safety valve • 24 V dead man controls • Automatic release of safety locking devices • Sound dampening of safety locks • Manual descent valve • Max. lifting height of platforms 1950mm**
-  Seilbruchsicherung • Überdruckventil gegen Überlastung • Senksteuerventil • Rohrbruchsicherung • 24 V-Totmann-Steuerung • Automatische Entriegelung der Lastsicherungshebel vor dem Absenken • Schalldämpfung der Lastsicherungshebel • Manuelles Senkventil • Max. Höhe der Fahrschienen 1950 mm
-  Sécurité en cas de rupture du câble • Vanne de surpression contre surcharges • Vanne de réglage descente • Vanne d'arrêt en cas de rupture de la tuyauterie • Commandes de type homme mort à 24 V • Déclanchement automatique des crochets • Insonorisation des sécurités mécaniques • Vanne manuelle de descente • Hauteur max. des chemins de roulement 1950 mm
-  Seguridad en caso de rotura del cable de acero • Seguridad hidráulica contra la sobrecarga • Válvula de regulación descenso • Seguridad hidráulica en caso de rotura de tubos hidráulicos • Mandos de hombre presente, 24V • Desenganche automático de las seguridades para el descenso • Insonorización seguridades • Válvula manual de control del descenso • Altura máxima plataformas 1950mm

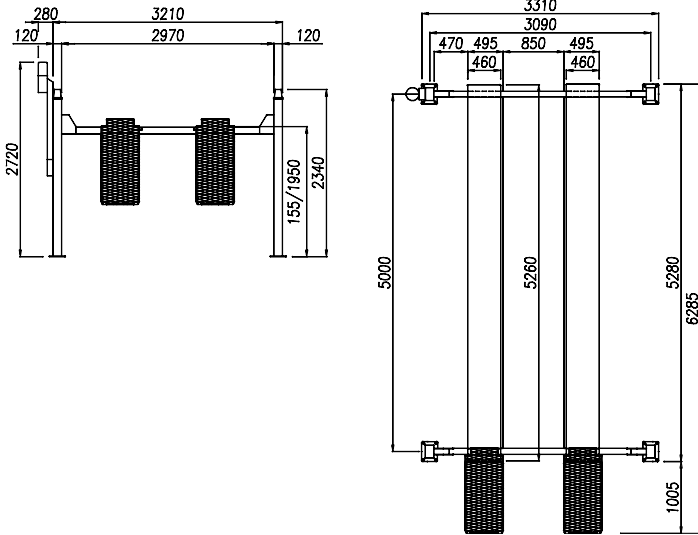

Dati tecnici	Technical data	Technische Eigenschaften	Caractéristiques techniques	Datos técnicos	
Portata	Capacity	Tragfähigkeit	Capacité	Capacidad	5.000 kg
Peso	Weight	Gewicht	Poids	Peso	980 kg
Salita/Discesa	Lifting/descent	Hub/Senkzeit	Levage/descente	Subida/Bajada	35/35 s
Altezza di sollevamento	Lifting height	Hubhöhe	Hauteur de levage	Altura de elevación	1950 mm
Motore	Motor	Motorleistung	Puissance moteur	Motor	3,0 kW - 3 ph 230 400V/50 Hz

Funzionamento: Elettroidraulico • **Function: Electro-hydraulic** • Funktionsweise: Elektrohydraulisch • Fonctionnement: Electrohydraulique • Funcionamiento: Electro-hidráulico

Opzioni **Optionals** **Sonderzubehör** **Options** **Opcionales**

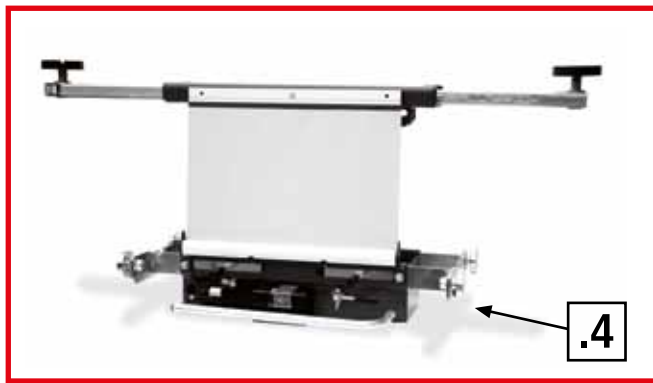

Traversa idraulica ausiliaria (vedere scheda specifica)
Hydraulic jacking beam (see relevant data sheet)
 Hydraulischer Radfreiheber (s. eigenes Datenblatt)
 Levage auxiliaire hydraulique (voir fiche technique)
 Elevador hidráulico auxiliar (ver ficha técnica)



Platti Rotanti
Radius plates
 Drehplatten
 Plaques pivotantes
 Platos giratorios

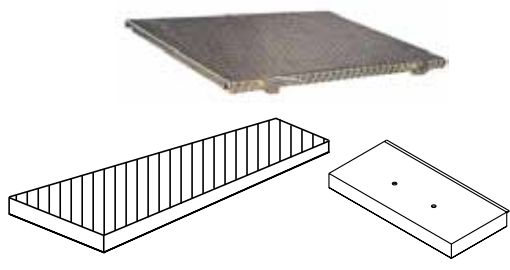

Kit per assetto ruote (piastre oscillanti posteriori+ tamponamenti centrali + distanziali per piastre rotanti anteriori)
Wheel alignment set (rear slip plates + middle alignment covers + front spacers for radius plates)
 Zusatz für Achsvermessung (hintere Schiebepplatten + mittlere Nivellier-platten + vordere Abstandhalter f. Drehplatten)
 Jeu supplémentaire pour géométrie (plaques arrière + plaques centrales d'alignement + entretoises avant pour plaques tournantes)
 Kit para alineación de ruedas (platos oscilantes traseros + placas centrales para alineación + distanciadores para platos giratorios delanteros)

The company reserves the right to introduce improvements in design or specification without prior notice







450/3DA

5,0 t

CE



-  Sollevatore elettroidraulico a 4 colonne alta velocità con pedane strette per assetto ruote 3D
-  **Electro-hydraulic high speed 4 post-lift with narrow platforms for 3D-wheel-alignment**
-  Elektrohydraulische 4-Säulen Hebebühne, mit hoher Hubgeschwindigkeit, schmale Fahrschienen für 3D-Achsvermessung
-  Pont élévateur Electrohydraulique. 4 colonnes grande vitesse avec chemins de roulement étroits pour contrôle train avant 3D
-  Elevador electro-hidráulico de 4 columnas alta velocidad con plataformas estrechas para alineación 3D de las ruedas



450/3DA

**

Assetto ruote non incluso
Wheel alignment not included
 Achsvermessung gehört nicht z. Lieferumfang
 Géométrie n'est pas incluse
 Alineador de ruedas no incluido

 Sicurezza in caso di rottura fune • Sicurezza idraulica contro il sovraccarico • Valvola regolazione discesa • Sicurezza idraulica in caso di rottura tubi idraulici • Comandi uomo presente 24 V • Sgancio automatico delle sicurezze per la discesa • Insonorizzazione sicurezze • Valvola manuale controllo discesa • Massima altezza pedane 1950mm • 3DA: Kit per assetto ruote montato (piastre oscillanti posteriori + tamponamenti centrali + distanziali per piastre rotanti anteriori)





 **Safety device in case of rope breaking • Overload safety valve • Descent control valve • Pipe burst safety valve • 24 V dead man controls • Autoamatic disengagement of the safety wedges prior to descent • Sound dampening of safety locks • Manual descent valve • Max. lifting height of platforms 1950mm • 3DA: Wheel alignment set installed on the lift (rear slip plates + middle alignment covers + front spacers for radius plates)**

 Seilbruchsicherung • Überdruckventil gegen Überlastung • Senksteuerventil • Rohrbruchsicherung • 24 V-Totmann-Steuerung • Automatische Entriegelung der Lastsicherungshebel vor dem Absenken • Schalldämpfung der Lastsicherungshebel • Manuelles Senkventil • Max. Höhe der Fahrschienen 1950 mm • 3DA: Zusatzset für Achsvermessung bereits vormontiert (hintere Schiebepplatten + mittlere Nivellierplatten + vordere Abstandhalter f. Drehplatten)

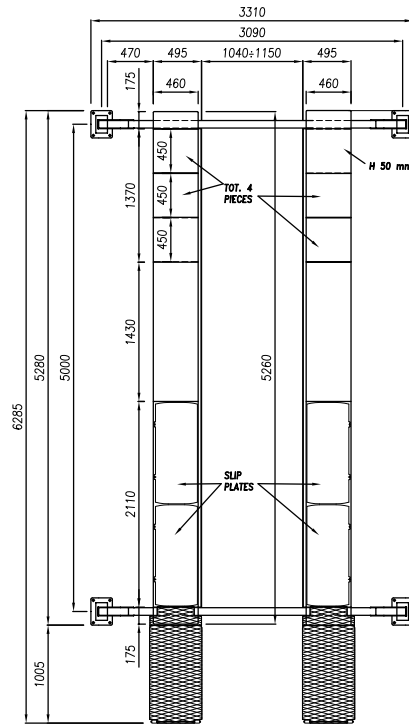
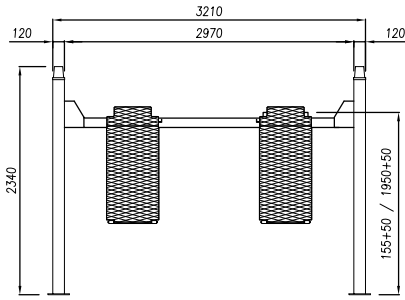
 Sécurité en cas de rupture du câble • Vanne de surpression contre surcharges • Vanne de réglage descente • Vanne d'arrêt en cas de rupture de la tuyauterie • Commandes de type homme mort à 24 V • Déclanchement automatique des crochets • Insonorisation des sécurités mécaniques • Vanne manuelle de descente • Hauteur max. des chemins de roulement 1950 mm • 3DA: Jeu supplémentaire pour géométrie installé (plaques arrière + plaques centrales d'alignement + entretoises avant pour plaques tournantes)

 Seguridad en caso de rotura del cable de acero • Seguridad hidráulica contra la sobrecarga • Válvula de regulación descenso • Seguridad hidráulica en caso de rotura de tubos hidráulicos • Mandos de hombre presente, 24V • Desenganche automático de las seguridades para el descenso • Insonorización seguridades • Válvula manual de control del descenso • Altura máxima plataformas 1950mm • 3DA: Kit para alineación de ruedas montado (platos oscilantes traseros + placas centrales para alineación + distanciadores para platos giratorios delanteros)



 Dati tecnici	 Technical data	 Technische Eigenschaften	 Caractéristiques techniques	 Datos técnicos	
Portata	Capacity	Tragfähigkeit	Capacité	Capacidad	5.000 kg
Peso	Weight	Gewicht	Poids	Peso	980 kg
Salita/Discesa	Lifting/descent	Hub/Senkzeit	Levage/descente	Subida/Bajada	35/35 s
Altezza di sollevamento	Lifting height	Hubhöhe	Hauteur de levage	Altura de elevación	1950 mm
Motore	Motor	Motorleistung	Puissance moteur	Motor	3,0 kW - 3 ph 230 400V/50 Hz

Funzionamento: Elettroidraulico • **Function: Electro-hydraulic** • Funktionsweise: Elektrohydraulisch • Fonctionnement: Electrohydraulique
 • Funcionamiento: Electro-hidráulico

 **Opzioni**  **Optionals**  **Sonderzubehör**  **Options**  **Opcionales**



Traversa idraulica ausiliaria (vedere scheda specifica)
Hydraulic jacking beam (see relevant data sheet)
 Hydraulischer Radfreiheber (s. eigenes Datenblatt)
 Levage auxiliaire hydraulique (voir fiche technique)
 Elevador hidráulico auxiliar (ver ficha técnica)



Piatti Rotanti
Radius plates
 Drehplatten
 Plaques pivotantes
 Platos giratorios



450ATLT - 450ATLT PG 5,0 t

CE



 Sollevatore elettroidraulico a 4 colonne con incavi anteriori e piastre oscillanti posteriori per allineamento ruote e sollevatore ausiliario incorporato

 **Electro-hydraulic 4 post lift with front recesses and rear slipping plates for wheel alignment and built in lifting table**

 Elektrohydraulische 4-Säulen-Hebebühne mit vorderen Aussparungen und hinteren Schiebeplatten für die Achsvermessung und eingebautem Radfreiheber

 Pont élévateur électro-hydraulique à 4 colonnes avec encastremets avant et plaques arrière pour géométrie et levage auxiliaire incorporé

 Elevador electro-hidráulico de 4 columnas con asientos delanteros y platos oscilantes traseros para alineación de ruedas y Elevador auxiliar incorporado





* 450 ATLT

Carter protezione centralina
Cover for control unit
Abdeckung für Hydraulikaggregat
Carter protection centrale hydraulique
Cubierta protectora para la centralita

Sollevatore ausiliario da 4,0 t
Lifting table with 4,0 t capacity
Radfreiheber 4,0 t Tragkraft
Levage auxiliaire capacité 4,0 t
Elevador auxiliar de 4,0 t

* Optional

 Sicurezza idraulica contro il sovraccarico • Valvola regolazione discesa • Segnale acustico ultimo tratto di discesa • Sicurezza idraulica in caso di rottura tubi idraulici • Comandi uomo presente 24 V • Sgancio automatico delle sicurezze per la discesa

 **Overload safety valve • Descent control valve • "Buzzer" on last portion of descent • Pipe burst safety valve • 24 V, low tension dead man controls • Automatic release of safety locking devices**

 Überdruckventil als Überlastsicherung • Senksteuerventil • Akustisches Signal im letzten Teil der Senkbewegung • Rohrbruch-Sicherheitsventil • 24 V-Totmannschaltung • Automatische Entriegelung der Lastsicherungshebel vor dem Absenken

 Vanne de surpression contre surcharges • Vanne de réglage descente • Signal sonore sur la dernière partie de descente • Vanne d'arrêt en cas de rupture de la tuyauterie • Commandes de type homme mort à 24 V • Déclanchement automatique des crochets lors de la descente

 Seguridad hidráulica contra la sobrecarga • Válvula de regulación del descenso • Señal acústica último tramo de descenso • Seguridad hidráulica en caso de rotura tubos hidráulicos • Mandos de hombre presente, 24V • Desenganche automático de las seguridades para el descenso

450ATLT - 450ATLT PG 5,0 t

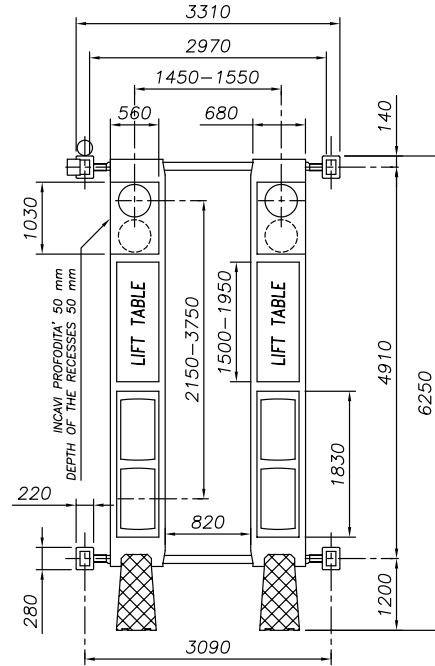
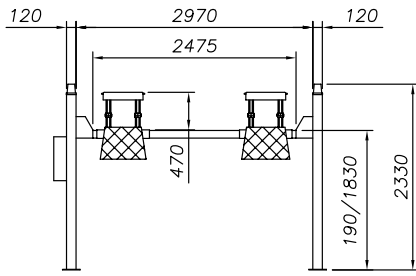

450ATLT PG

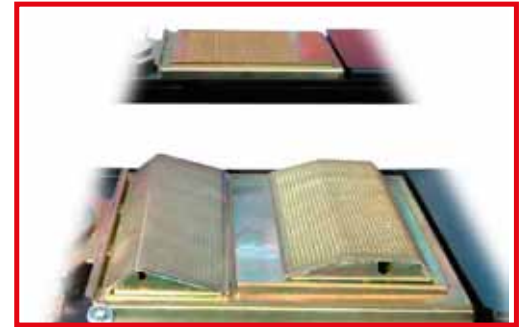

Dati tecnici	Technical data	Technische Eigenschaften	Caractéristiques techniques	Datos técnicos	
Portata	Capacity	Tragfähigkeit	Capacité	Capacidad	5.000 kg
Peso	Weight	Gewicht	Poids	Peso	980 kg
Salita/Discesa	Lifting/descent	Hub/Senkzeit	Levage/descente	Subida/Bajada	35/35 s
Altezza di sollevamento	Lifting height	Hubhöhe	Hauteur de levage	Altura de elevación	1950 mm
Motore	Motor	Motorleistung	Puissance moteur	Motor	3,0 kW - 3 ph 230 400V/50 Hz

Funzionamento: Elettroidraulico • **Function: Electro-hydraulic** • Funktionsweise: Elektrohydraulisch • Fonctionnement: Electrohydraulique
 • Funcionamiento: Electro-hidráulico

Opzioni	Optionals	Sonderzubehör	Options	Opcionales
---------	-----------	---------------	---------	------------



Piatti Rotanti
Radius plates
 Drehplatten
 Plaques pivotantes
 Platos giratorios

Esecuzione con motore monofase • Kit illuminazione • Disponibili versioni corrispondenti a normative specifiche (M.O.T.) • Carter protezione centralina

Single-phase motor • Illumination kit • Versions according to specific rules available (M.O.T.) • Cover for control unit

Ausführung mit Einphasenmotor • Beleuchtungsset • Es sind Ausführungen nach spezifischen Normen lieferbar (M.O.T.) • Abdeckung für Hydraulikaggregat

Moteur monophasé • Kit d'éclairage • On peut livrer versions correspondantes à normes spécifiques (M.O.T.) • Carter protection centrale hydraulique

Motor monofásico • Kit de iluminación • Disponibles versiones correspondientes a normas específicas (M.O.T.) • Cubierta protectora para la centralita





The company reserves the right to introduce improvements in design or specification without prior notice



402M/402P

1,6 t



-  Traversa idrauliche
-  Hydraulic jacking beams
-  Hydraulische Achsfreiheber
-  Traverses hydrauliques
-  Travesaños hidráulicos



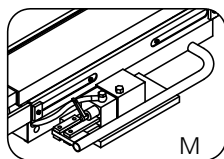
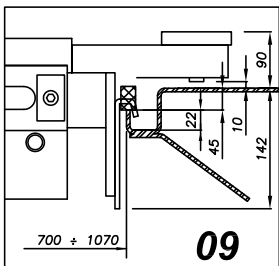
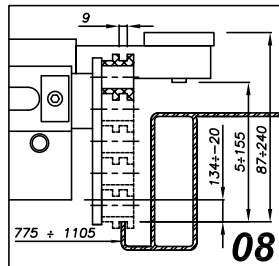
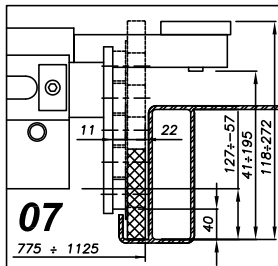
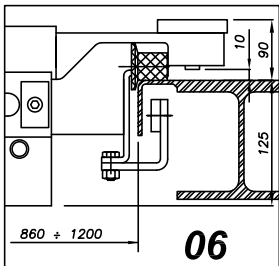
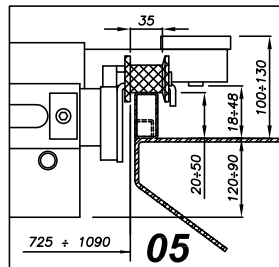
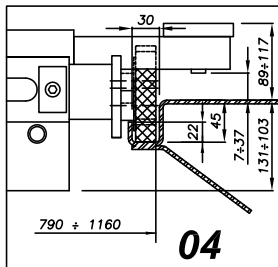
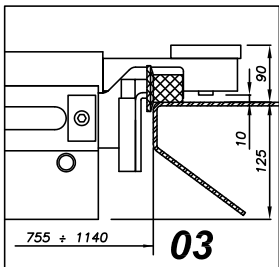

 Modelli disponibili  Available versions  Lieferbare Ausführungen  Versions Disponibles  Versiones disponibles

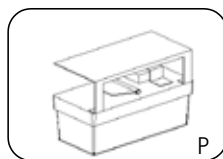

Pompa manuale
Pompe manuelle
Manual pump
Handpumpe



Pompa pneumatica
Pompe pneumatique
Pneumatic pump
Pneumatischer Pumpe

-  Sollevatore / Pont élévateur / Lift / Säulen / Elevador
-  Rullo / Galet / Roller / Rolle / Rodillo

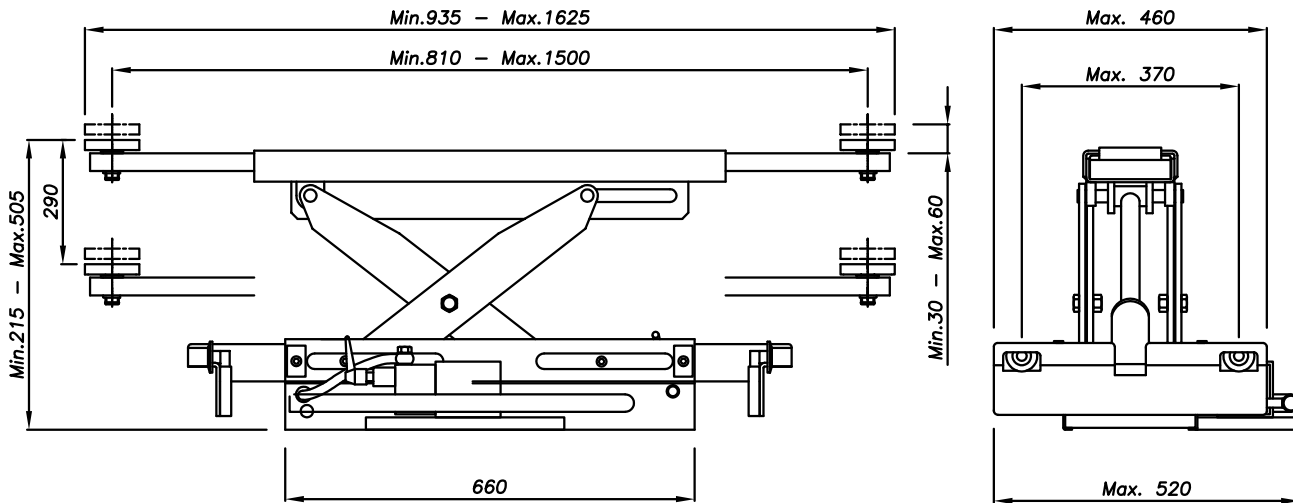

Dati tecnici	Technical data	Technische Eigenschaften	Caractéristiques techniques	Datos técnicos	
Portata	Capacity	Hubkraft	Capacité	Capacidad	1.600 kg
Spostamento vert. del carico	Lifting height	Hubhöhe	Hauteur de levée	Desplazamiento vert. de la carga	290 mm
Estensione min (bracci chiusi)	Min extension (arms retracted)	Min. Aufnahmebreite (Arme voll eingefahren)	Extension min. des bras (bras rentrés)	Extensión mín. (brazos cerrados)	935 mm
Estensione max. (bracci aperti)	Max. extension (arms extracted)	Max. Aufnahmebreite (Arme voll ausgefahren)	Extension max des bras (bras sortis)	Extensión máx. (brazos abiertos)	1.625 mm
Scartamento delle ruote di scorrimento	Gauge	Spurweite	Ecartement des roulettes	Ancho de via	vedere dettagli schemi - please refer to carriage diagrams
Peso della traversa	Weight	Gewicht	Poids	Peso del travesaño	105 kg

Opzioni **Optionals** **Sonderzubehör** **Options** **Opcionales**



<ul style="list-style-type: none"> • Kit appoggi per traversa • Support kit for jacking beam • Stützesatz für Achsfreiheber • Jeu de supports pour traverse • Kit soportes para travesaños 	L1166
--	-------



<ul style="list-style-type: none"> • Estensioni per tamponi di sollevamento • Lifting pad extensions • Hubspindelverlängerungen • Rallonges pour tampons de levage • Extensiones para tacos de elevación 	• 60 mm	L1198
	• 100 mm	L1277

The company reserves the right to introduce improvements in design or specification without prior notice



402/2M - 402/2P

2,0 t



- Traversa idrauliche
- Hydraulic jacking beams
- Hydraulische Achsfreiheber
- Traverses hydrauliques
- Travesaños hidráulicos



Modelli disponibili
 Versions disponibles
 Lieferbare Ausführungen
 Available versions
 Versiones disponibles

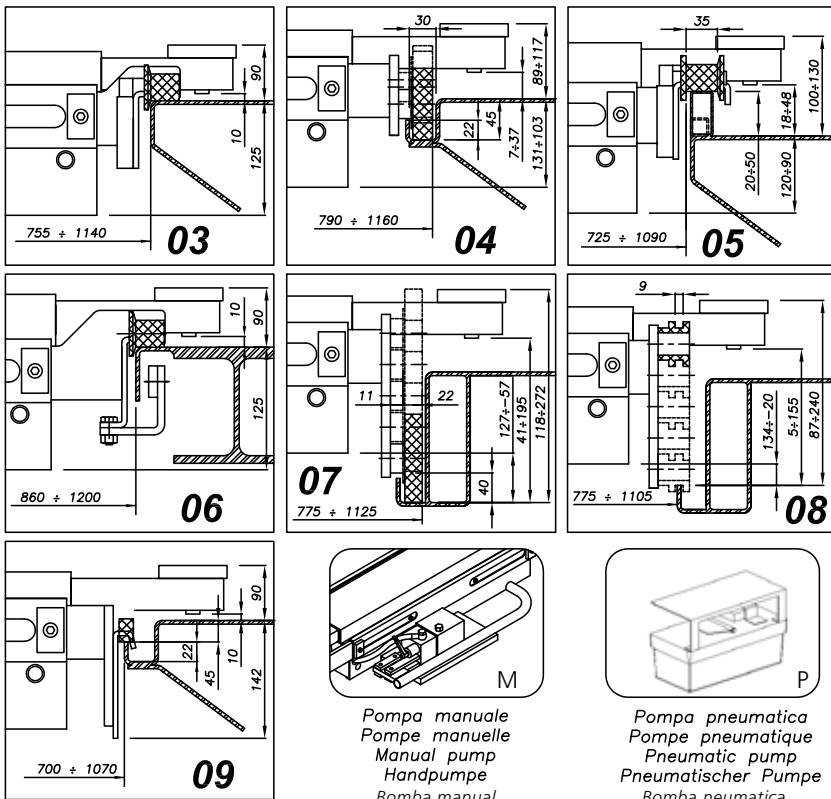

- Sollevatore / Pont élévateur / Lift / Säulen / Elevador
- Rullo / Galet / Roller / Rolle / Rodillo

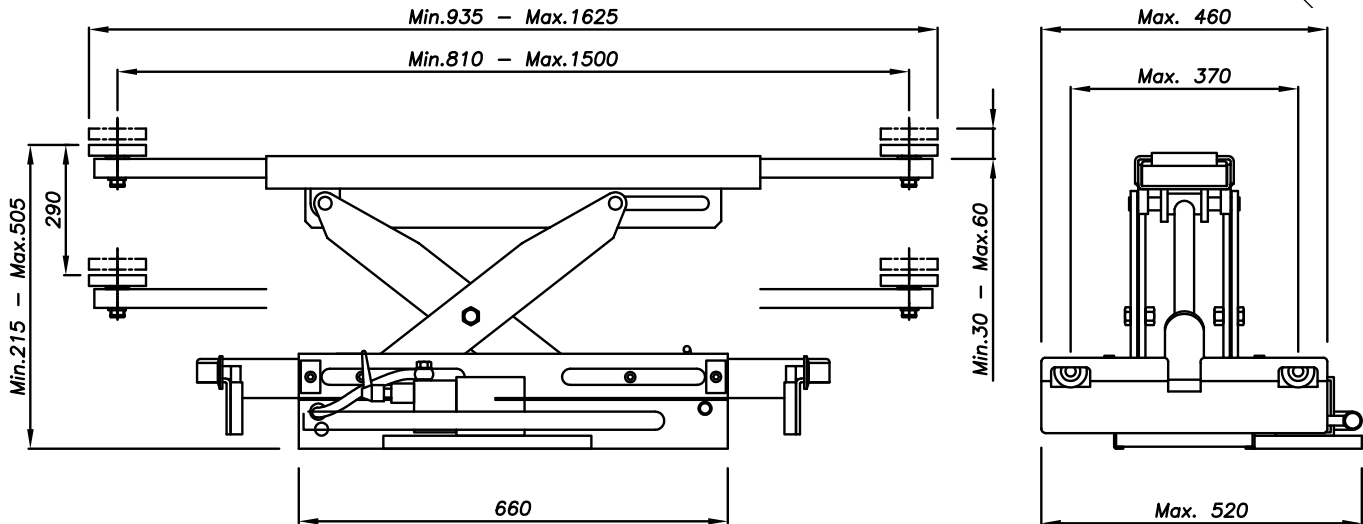

Dati tecnici	Technical data	Technische Eigenschaften	Caractéristiques techniques	Datos técnicos	
Portata	Capacity	Hubkraft	Capacité	Capacidad	2.000 kg
Spostamento vert. del carico	Lifting height	Hubhöhe	Hauteur de levée	Desplazamiento vert. de la carga	300 mm
Estensione min (bracci chiusi)	Min extension (arms retracted)	Min. Aufnahmebreite (Arme voll eingefahren)	Extension min. des bras (bras rentrés)	Extensión mín. (brazos cerrados)	935 mm
Estensione max. (bracci aperti)	Max. extension (arms extracted)	Max. Aufnahmebreite (Arme voll ausgefahren)	Extension max des bras (bras sortis)	Extensión máx. (brazos abiertos)	1.620 mm
Scartamento delle ruote di scorrimento	Gauge	Spurweite	Ecartement des roulettes	Ancho de vía	vedere dettagli schemi - please refer to carriage diagrams
Peso della traversa	Weight	Gewicht	Poids	Peso del travesaño	105 kg

Opzioni **Optionals** **Sonderzubehör** **Options** **Opcionales**

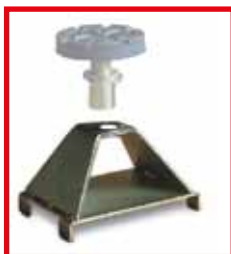

<ul style="list-style-type: none"> • Kit appoggi per traversa • Support kit for jacking beam • Stützesatz für Achsfreiheber • Jeu de supports pour traverse • Kit soportes para travesaños 	L1166
--	-------



<ul style="list-style-type: none"> • Estensioni per tamponi di sollevamento • Lifting pad extensions • Hubspindelverlängerungen • Rallonges pour tampons de levage • Extensiones para tacos de elevación 	• 60 mm	L1198
	• 100 mm	L1277

The company reserves the right to introduce improvements in design or specification without prior notice



- Traversa idrauliche
- Hydraulic jacking beams
- Hydraulische Achsfreiheber
- Traverses hydrauliques
- Travesaños hidráulicos



Modelli disponibili
 Available versions
 Lieferbare Ausführungen
 Versions Disponibles
 Versiones disponibles

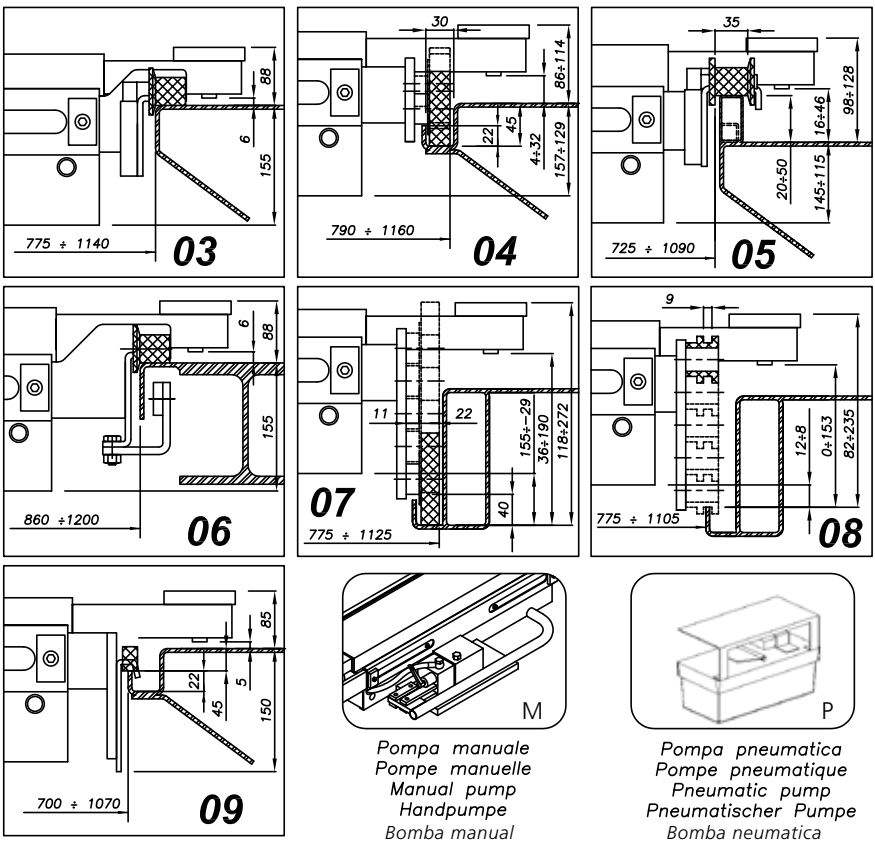

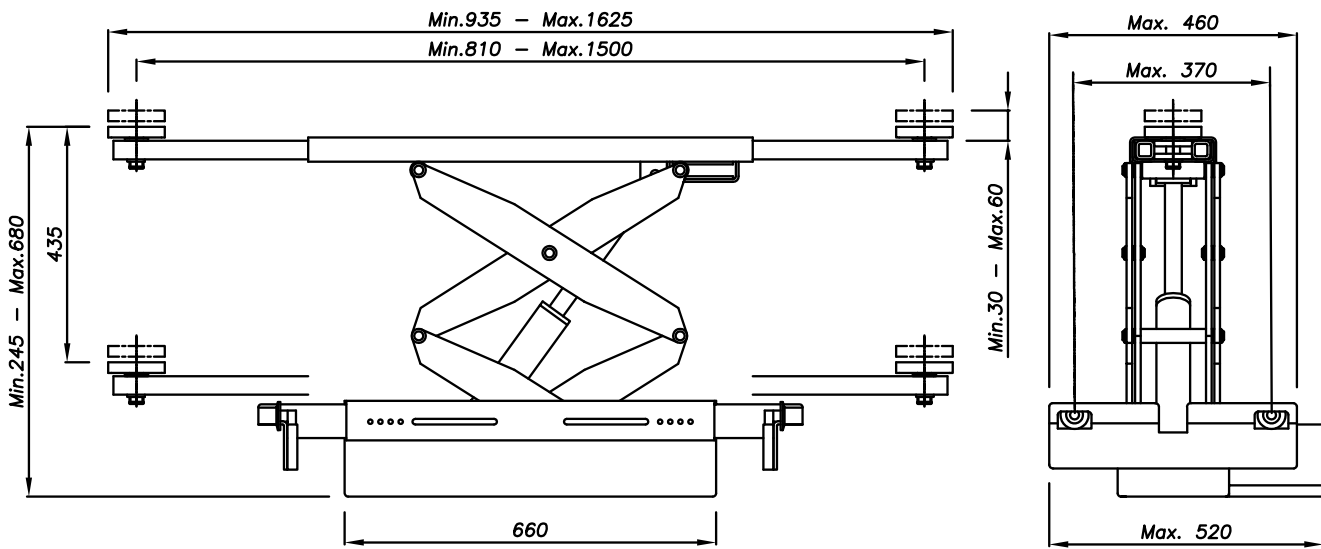

Dati tecnici	Technical data	Technische Eigenschaften	Caractéristiques techniques	Datos técnicos	
Portata	Capacity	Hubkraft	Capacité	Capacidad	2.000 kg
Spostamento vert. del carico	Lifting height	Hubhöhe	Hauteur de levée	Desplazamiento vert. de la carga	435 mm
Estensione min (bracci chiusi)	Min extension (arms retracted)	Min. Aufnahmebreite (Arme voll eingefahren)	Extension min. des bras (bras rentrés)	Extensión mín. (brazos cerrados)	935 mm
Estensione max. (bracci aperti)	Max. extension (arms extracted)	Max. Aufnahmebreite (Arme voll ausgefahren)	Extension max des bras (bras sortis)	Extensión máx. (brazos abiertos)	1.625 mm
Scartamento delle ruote di scorrimento	Gauge	Spurweite	Ecartement des roulettes	Ancho de via	vedere dettagli schemi - please refer to carriage diagrams
Peso della traversa	Weight	Gewicht	Poids	Peso del travesaño	135 kg

Opzioni	Optionals	Sonderzubehör	Options	Opcionales
----------------	------------------	----------------------	----------------	-------------------



<ul style="list-style-type: none"> • Kit appoggi per traversa • Support kit for jacking beam • Stützesatz für Achsfreiheber • Jeu de supports pour traverse • Kit soportes para travesaños 	L1166
--	-------



<ul style="list-style-type: none"> • Estensioni per tamponi di sollevamento • Lifting pad extensions • Hubspindelverlängerungen • Rallonges pour tampons de levage • Extensiones para tacos de elevación 	• 60 mm	L1198
	• 100 mm	L1277





The company reserves the right to introduce improvements in design or specification without prior notice



496/3M-496/3P

3,0 t



-  Traverse idrauliche
-  Hydraulic jacking beams
-  Hydraulische Achsfreiheber
-  Traverses hydrauliques
-  Travesaños hidráulicos



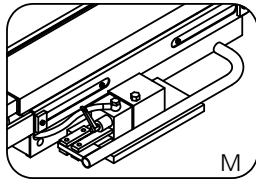
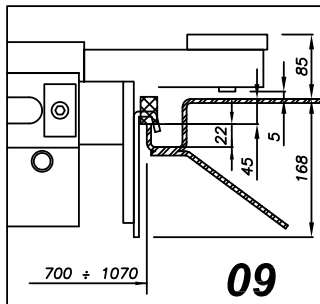
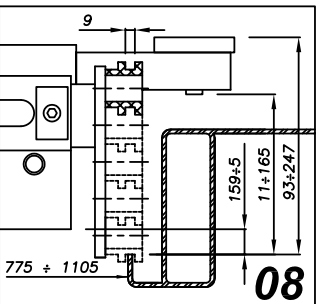
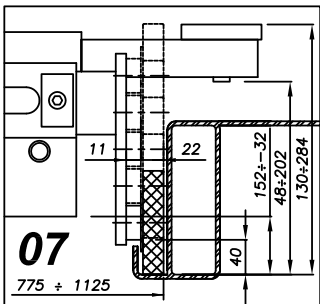
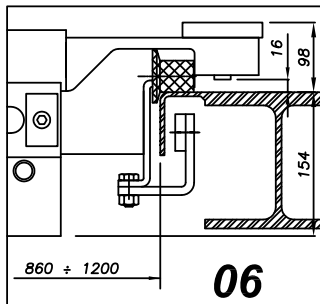
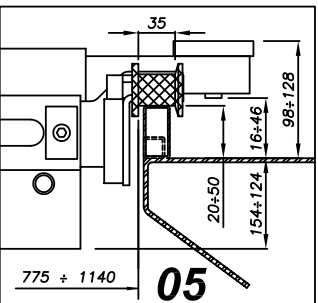
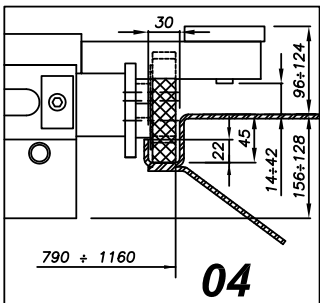
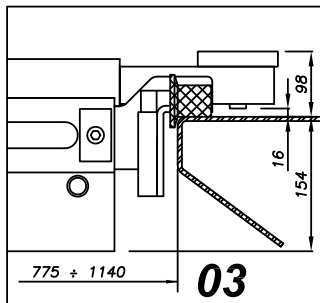

 **Modelli disponibili**  **Available versions**  **Lieferbare Ausführungen**  **Versions Disponibles**  **Versiones disponibles**

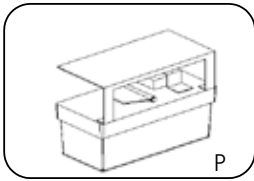

*Pompa manuale
Pompe manuelle
Manual pump
Handpumpe
Bomba manual*



*Pompa pneumatica
Pompe pneumatique
Pneumatic pump
Pneumatischer Pumpe
Bomba neumatica*

-  Sollevatore / Pont élévateur / Lift / Säulen / Elevador
-  Rullo / Galet / Roller / Rolle / Rodillo

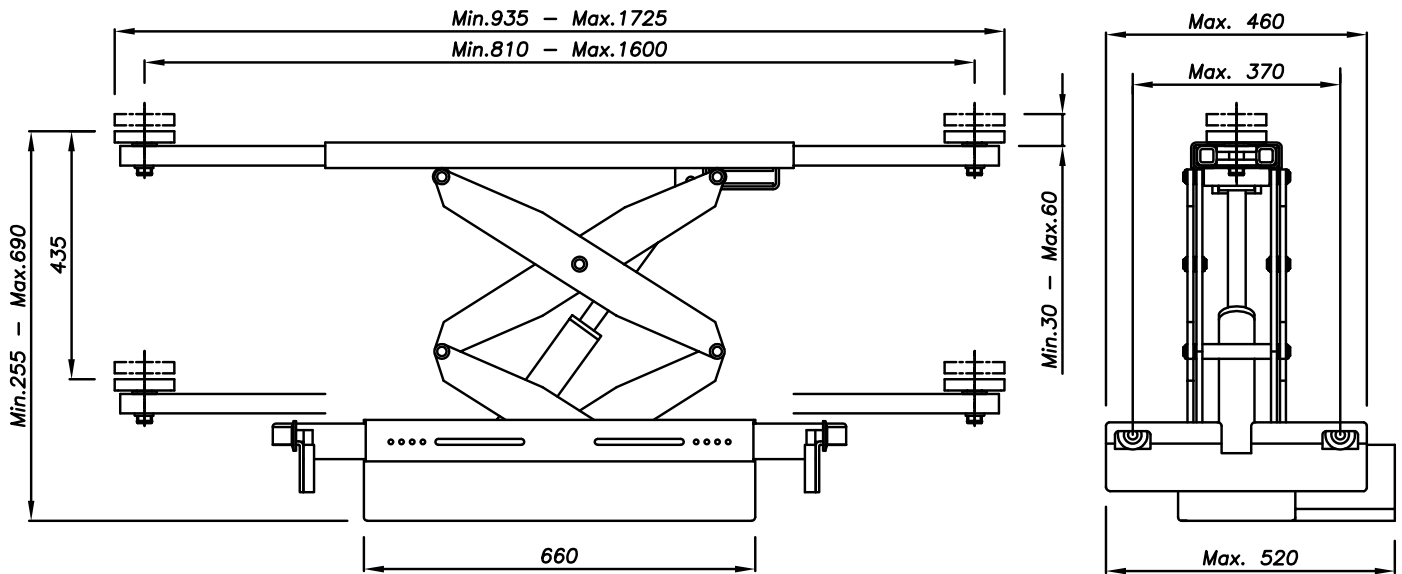

Dati tecnici	Technical data	Technische Eigenschaften	Caractéristiques techniques	Datos técnicos	
Portata	Capacity	Hubkraft	Capacité	Capacidad	3.000 kg
Spostamento vert. del carico	Lifting height	Hubhöhe	Hauteur de levée	Desplazamiento vert. de la carga	435 mm
Estensione min (bracci chiusi)	Min extension (arms retracted)	Min. Aufnahmebreite (Arme voll eingefahren)	Extension min. des bras (bras rentrés)	Extensión mín. (brazos cerrados)	935 mm
Estensione max. (bracci aperti)	Max. extension (arms extracted)	Max. Aufnahmebreite (Arme voll ausgefahren)	Extension max des bras (bras sortis)	Extensión máx. (brazos abiertos)	1.725 mm
Scartamento delle ruote di scorrimento	Gauge	Spurweite	Ecartement des roulettes	Ancho de via	vedere dettagli schemi - please refer to carriage diagrams
Peso della traversa	Weight	Gewicht	Poids	Peso del travesaño	150 kg

Opzioni **Optionals** **Sonderzubehör** **Options** **Opcionales**



<ul style="list-style-type: none"> • Kit appoggi per traversa • Support kit for jacking beam • Stützesatz für Achsfreiheber • Jeu de supports pour traverse • Kit soportes para travesaños 	L1166
--	-------



<ul style="list-style-type: none"> • Estensioni per tamponi di sollevamento • Lifting pad extensions • Hubspindelverlängerungen • Rallonges pour tampons de levage • Extensiones para tacos de elevación 	• 60 mm	L1198
	• 100 mm	L1277





The company reserves the right to introduce improvements in design or specification without prior notice



403M/403P

3,0 t



-  Traversa idrauliche
-  Hydraulic jacking beams
-  Hydraulische Achsfreiheber
-  Traverses hydrauliques
-  Travesaños hidráulicos



 **Modelli disponibili**  **Available versions**  **Lieferbare Ausführungen**  **Versions Disponibles**  **Versiones disponibles**

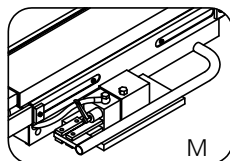
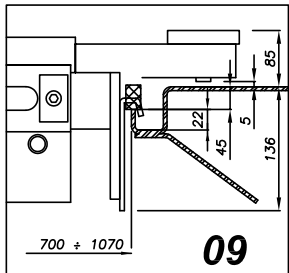
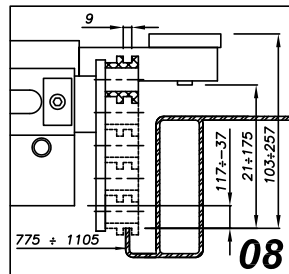
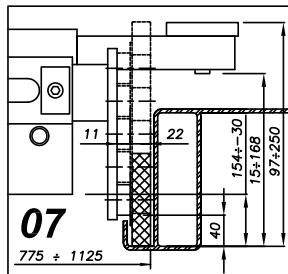
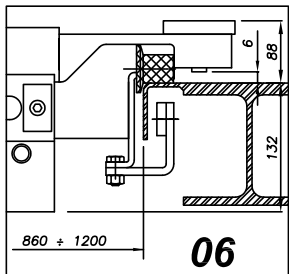
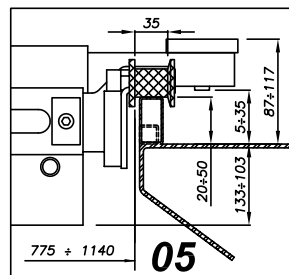
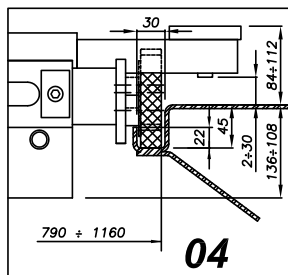
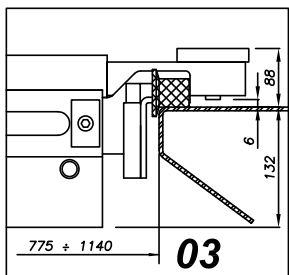

Pompa manuale
Pompe manuelle
Manual pump
Handpumpe
Bomba manual

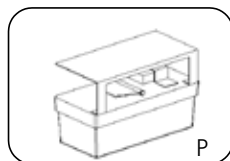

Pompa pneumatica
Pompe pneumatique
Pneumatic pump
Pneumatischer Pumpe
Bomba neumatica



Sollevatore / Pont élévateur / Lift / Säulen / Elevador



Rullo / Galet / Roller / Rolle / Rodillo

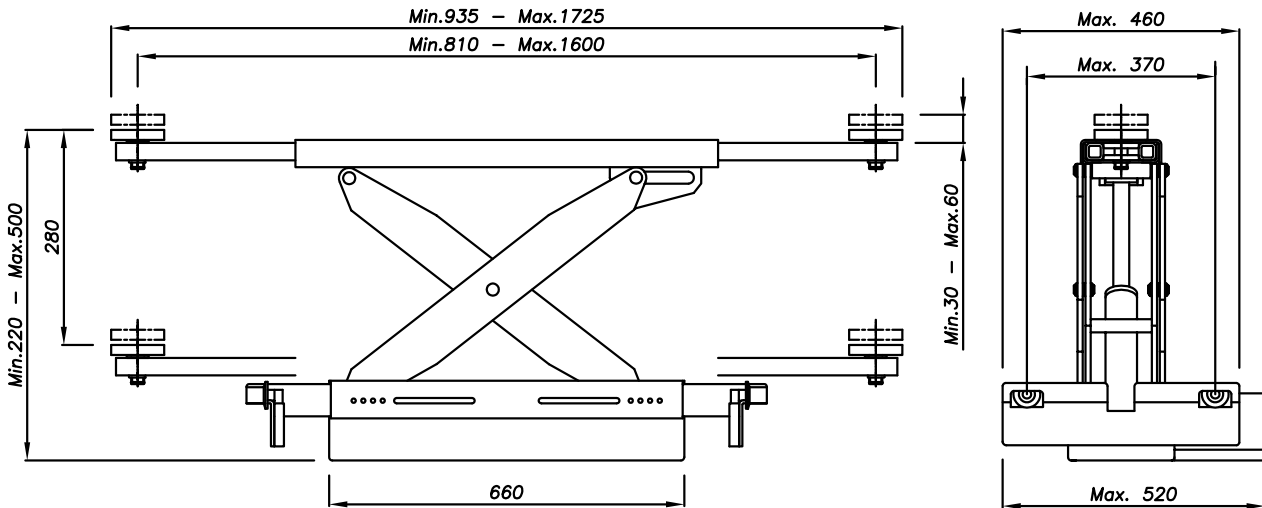

Dati tecnici	Technical data	Technische Eigenschaften	Caractéristiques techniques	Datos técnicos	
Portata	Capacity	Hubkraft	Capacité	Capacidad	3.000 kg
Spostamento vert. del carico	Lifting height	Hubhöhe	Hauteur de levée	Desplazamiento vert. de la carga	280 mm
Estensione min (bracci chiusi)	Min extension (arms retracted)	Min. Aufnahmebreite (Arme voll eingefahren)	Extension min. des bras (bras rentrés)	Extensión mín. (brazos cerrados)	935 mm
Estensione max. (bracci aperti)	Max. extension (arms extracted)	Max. Aufnahmebreite (Arme voll ausgefahren)	Extension max des bras (bras sortis)	Extensión máx. (brazos abiertos)	1.725 mm
Scartamento delle ruote di scorrimento	Gauge	Spurweite	Ecartement des roulettes	Ancho de via	vedere dettagli schemi - please refer to carriage diagrams
Peso della traversa	Weight	Gewicht	Poids	Peso del travesaño	135 kg

Opzioni **Optionals** **Sonderzubehör** **Options** **Opcionales**



<ul style="list-style-type: none"> • Kit appoggi per traversa • Support kit for jacking beam • Stützesatz für Achsfreiheber • Jeu de supports pour traverse • Kit soportes para travesaños 	L1166
--	-------



<ul style="list-style-type: none"> • Estensioni per tamponi di sollevamento • Lifting pad extensions • Hubspindelverlängerungen • Rallonges pour tampons de levage • Extensiones para tacos de elevación 	• 60 mm	L1198
	• 100 mm	L1277





The company reserves the right to introduce improvements in design or specification without prior notice



403T/M - 403T/P

3,0 t





-  Traverse idrauliche
-  Hydraulic jacking beams
-  Hydraulische Achsfreiheber
-  Traverses hydrauliques
-  Travesaños hidráulicos

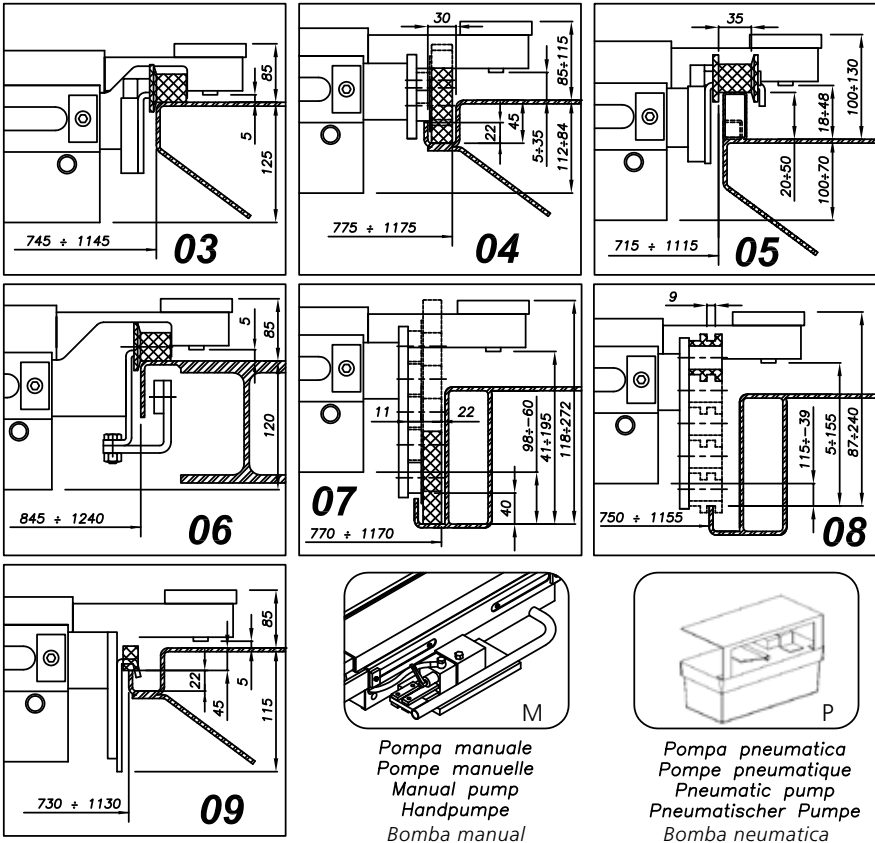

 **Modelli disponibili**  **Versions disponibles**  **Lieferbare Ausführungen**  **Available versions**  **Versiones disponibles**



-  Sollevatore / Pont élévateur / Lift / Säulen / Elevador
-  Rullo / Galet / Roller / Rolle / Rodillo

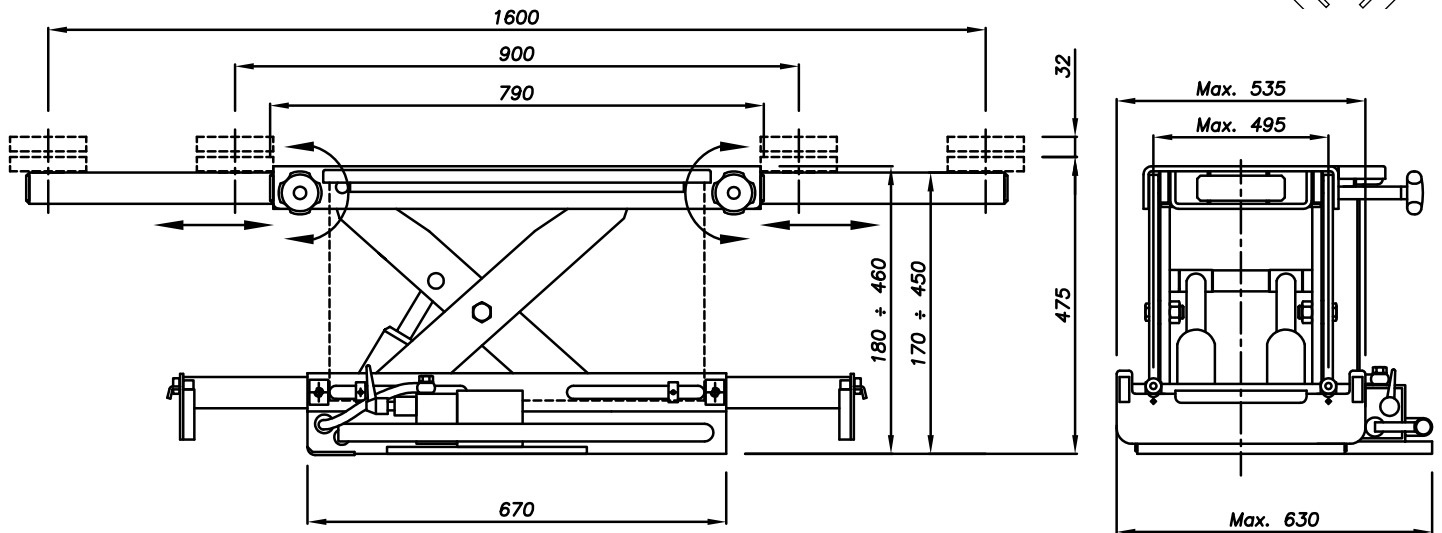

Dati tecnici	Technical data	Technische Eigenschaften	Caractéristiques techniques	Datos técnicos	
Portata	Capacity	Hubkraft	Capacité	Capacidad	3.000 kg
Spostamento vert. del carico	Lifting height	Hubhöhe	Hauteur de levée	Desplazamiento vert. de la carga	280 mm
Estensione min (bracci chiusi)	Min extension (arms retracted)	Min.Aufnahmebreite (Arme voll eingefahren)	Extension min. des bras (bras rentrés)	Extensión mín. (brazos cerrados)	790 mm
Estensione max. (bracci aperti)	Max. extension (arms extracted)	Max. Aufnahmebreite (Arme voll ausgefahren)	Extension max des bras (bras sortis)	Extensión máx. (brazos abiertos)	1.600 mm
Scartamento delle ruote di scorrimento	Gauge	Spurweite	Ecartement des roulettes	Ancho de vía	vedere dettagli schemi - please refer to carriage diagrams
Peso della traversa	Weight	Gewicht	Poids	Peso del travesaño	135 kg

Opzioni **Optionals** **Sonderzubehör** **Options** **Opcionales**

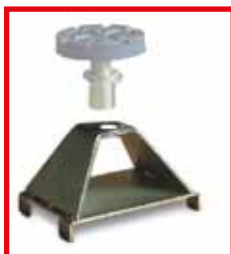

<ul style="list-style-type: none"> • Kit appoggi per traversa • Support kit for jacking beam • Stützesatz für Achsfreiheber • Jeu de supports pour traverse • Kit soportes para travesaños 	L1166
--	-------



<ul style="list-style-type: none"> • Estensioni per tamponi di sollevamento • Lifting pad extensions • Hubspindelverlängerungen • Rallonges pour tampons de levage • Extensiones para tacos de elevación 	• 60 mm	L1198
	• 100 mm	L1277





The company reserves the right to introduce improvements in design or specification without prior notice



404M/404P

4,0 t



-  Traverse idrauliche
-  Hydraulic jacking beams
-  Hydraulische Achsfreiheber
-  Traverses hydrauliques
-  Travesaños hidráulicos



 Modelli disponibili  Available versions  Lieferbare Ausführungen  Versions Disponibles  Versiones disponibles

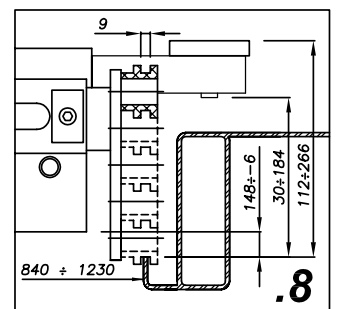
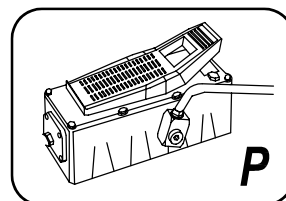
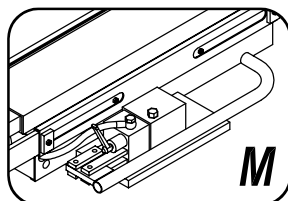
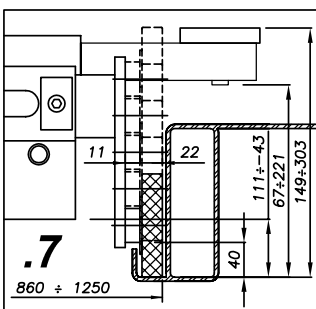
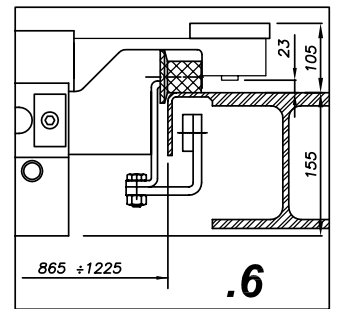
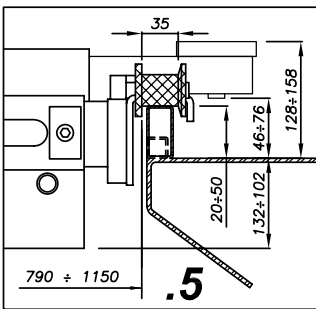

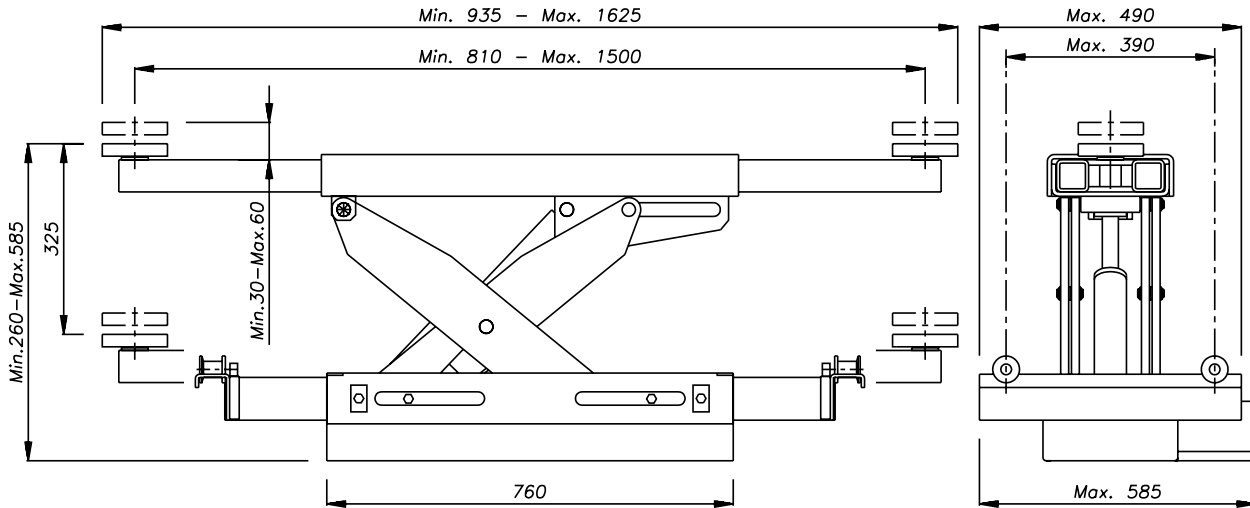

Dati tecnici	Technical data	Technische Eigenschaften	Caractéristiques techniques	Datos técnicos	
Portata	Capacity	Hubkraft	Capacité	Capacidad	4.000 kg
Spostamento vert. del carico	Lifting height	Hubhöhe	Hauteur de levée	Desplazamiento vert. de la carga	325 mm
Estensione min (bracci chiusi)	Min extension (arms retracted)	Min.Aufnahmebreite (Arme voll eingefahren)	Extension min. des bras (bras rentrés)	Extensión mín. (brazos cerrados)	935 mm
Estensione max. (bracci aperti)	Max. extension (arms extracted)	Max. Aufnahmebreite (Arme voll ausgefahren)	Extension max des bras (bras sortis)	Extensión máx. (brazos abiertos)	1.625 mm
Scartamento delle ruote di scorrimento	Gauge	Spurweite	Ecartement des roulettes	Ancho de via	vedere dettagli schemi - please refer to carriage diagrams
Peso della traversa	Weight	Gewicht	Poids	Peso del travesaño	180 kg

Opzioni **Optionals** **Sonderzubehör** **Options** **Opcionales**



<ul style="list-style-type: none"> • Estensioni per tamponi di sollevamento • Lifting pad extensions • Hubspindelverlängerungen • Rallonges pour tampons de levage • Extensiones para tacos de elevación 	• 60 mm	L1198
	• 100 mm	L1277







406P

6,0 t

CE



-  Traversa idraulica a forbice con pompa pneumatica
-  Hydraulic jacking beam with pneumatic pump
-  Hydraulischer Scherenheber mit pneumatischer Pumpe
-  Traverse hydraulique à ciseaux avec pompe pneumatique
-  Travesaño hidráulico à tijeras con bomba neumática





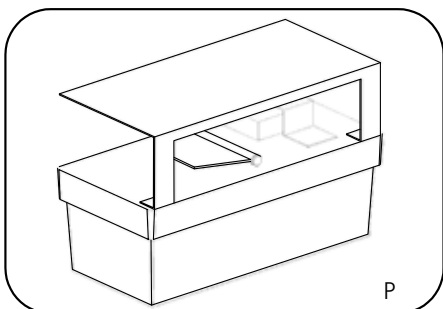
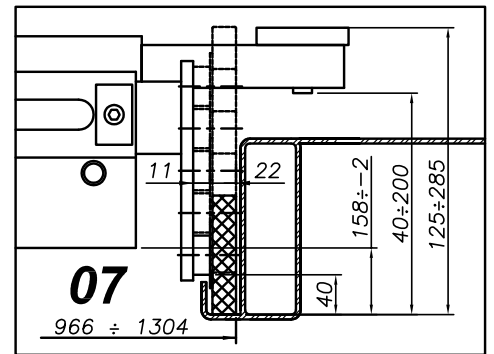
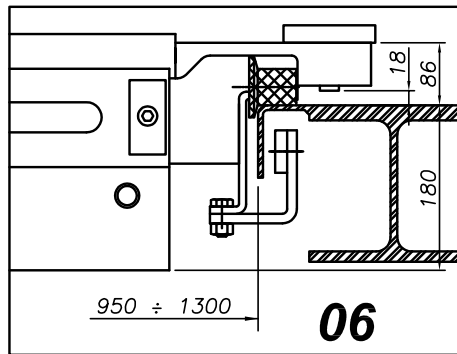
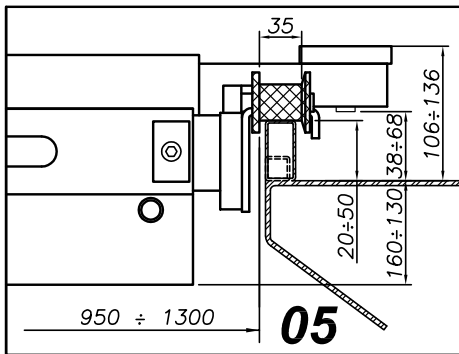



 Modelli disponibili  Available versions  Lieferbare Ausführungen  Versions Disponibles  Versiones disponibles

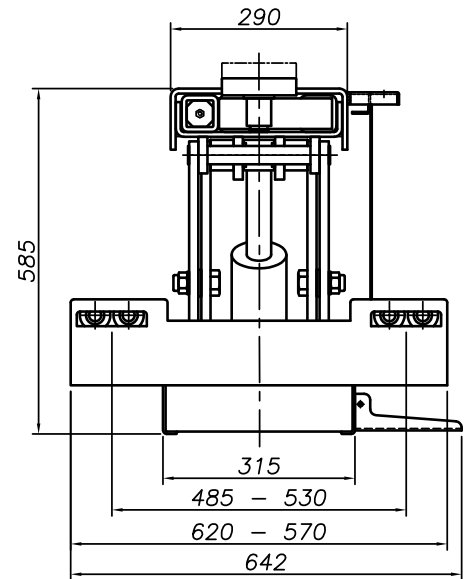
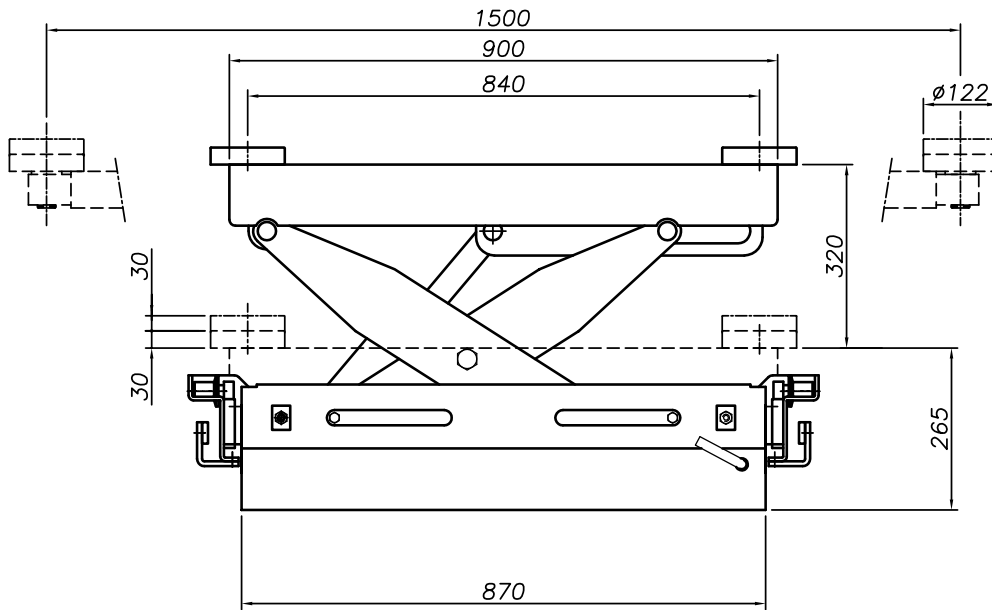

Pompa pneumatica
 Pompe pneumatique
 Pneumatic pump
 Pneumatischer Pumpe
 Bomba neumática

VARI • VARIOUS • VERSCHIEDENE • PLUSIÉURS • VARIOS



 Dati tecnici	 Technical data	 Technische Eigenschaften	 Caractéristiques techniques	 Datos técnicos	
Portata	Capacity	Hubkraft	Capacité	Capacidad	6.000 kg
Spostamento vert. del carico	Lifting height	Hubhöhe	Hauteur de levée	Desplazamiento vert. de la carga	320 mm
Estensione min (bracci chiusi)	Min extension (arms retracted)	Min.Aufnahmebreite (Arme voll eingefahren)	Extension min. des bras (bras rentrés)	Extensión mín. (brazos cerrados)	840 mm
Estensione max. (bracci aperti)	Max. extencion (arms extracted)	Max. Aufnahmebreite (Arme voll ausgefahren)	Extension max des bras (bras sortis)	Extensión máx. (brazos abiertos)	1.500 mm
Scartamento delle ruote di scorrimento	Gauge	Spurweite	Ecartement des roulettes	Ancho de via	vedere dettagli schemi - please refer to carriage diagrams
Peso della traversa	Weight	Gewicht	Poids	Peso del travesaño	260 kg

The company reserves the right to introduce improvements in design or specification without prior notice

W
E
R
T
H
E
R

W E R T H E R I N T E R N A T I O N A L S . P . A .



www.wertherint.com